

UNIVERSAL POWER CELLS



GIVES YOU VALUABLE INFORMATION ABOUT MACHINE AND PROCESS PERFORMANCE BY MONITORING MOTOR LOAD

- Mixture Viscosity
- Tool Condition
- Optimum Feed Rate
- Pump or Fan Flow
- Beginning or End Process
- Obstructions
- Overloads
- Loss of Load

THE UNIVERSAL POWER CELL SENSES TRUE MOTOR POWER—THREE PHASE, VARIABLE FREQUENCY, SINGLE PHASE OR DC

MODEL UPC

FULLY SELF CONTAINED

- Easy to install
- No Current Transformers
- No Voltage Transformers

COMPACT

- Only 1 3/4" x 5 3/8" x 8"

YOU CAN ADJUST FULL SCALE TO MATCH YOUR MOTOR

- Coarse and Fine Adjustment Pots
- 5HP to 150HP
- Take extra turns for small motors

VERSATILE

- Works on both Fixed and Variable Frequency Power
- ALSO Single Phase & DC

THREE BALANCED HALL EFFECT SENSORS

SAMPLE VOLTAGE DIRECTLY

- Up to 600 Volts

BUILT-IN POWER SUPPLY

- Powers the Analog Signals

BUILT-IN RESPONSE ADJUSTMENT

- Lets you slow the response of the Power Cell to average the readings

TWO ANALOG OUTPUTS

- 4-20 MA
- 0-10 Volts DC
- Electrically isolated



SUITABLE FOR INVERTER OUTPUTS
Immediate Shipment From Stock

SPECIAL PURPOSE UNIVERSAL POWER CELLS



UPC-LB

UPC-230 230 Volt Power Supply Input

UPC-FR Fast Response Universal Power Cell

- 0.050 Second Response Time
- Ideal for Machine Tool Monitoring
- Also used together with "V" Series Load Controls

UPC-LB Larger Holes

- For wires up to 0.9" (23 mm) diameter
- Nearly 50% more area than a standard UPC

UPC-KWH Energy Measuring Universal Power Cell

- Accumulates Kilowatt Hours, Kilowatt Minutes, Kilowatt Seconds
- Accumulates total power into the mixing process for consistent batches.
- Accumulates power—indicative of throughput.

Field Scalable - 3 to 100 KW

Pulse - Dry contact

Analog Output - 0-10 Volts

The UPC-KWH measures true power (KW) and momentarily pulses a relay contact every KWH, KWM, or KWS which is selectable. The pulse can signal a computer, meter or counter for power totalizing. An analog 0-10 Volt output reflects the instantaneous power and can input a meter or computer directly.

For Meters See -

- DM-100 Digital Load Meter
- KWH-3 Energy Meter

TYPICAL INSTALLATION-UPC

The Universal Power Cell is a Motor Load Sensor that monitors power (HP or KW). It works on both fixed and variable frequency power and has two analog outputs. It also works on single phase, DC, and brushless DC. The Universal Power Cell has Three Balanced Hall Effect Sensors, each with a flux concentrator. Each phase passes through a window. A voltage sample for each phase is also taken. The Hall Effect Semiconductor does a vector multiplication of the current flow and voltage which also calculates the power factor. The output is proportional to power (HP or KW).

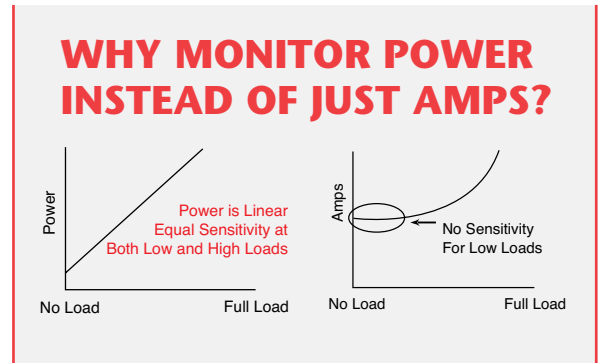

INPUT CONNECTIONS

Pass each of the phases through the L1, L2, L3 holes in the Cell. Be certain direction is correct. The Terminal side of the Cell faces the supply. Provide voltage sample for each phase. When a Variable Frequency Drive is being used, locate the Power Cell on the output side of the drive. Take the voltage samples on the output side also.

- L1 Volts to Terminal 7
- L2 Volts to Terminal 8
- L3 Volts to Terminal 9

ANALOG OUTPUTS

The Analog Output is powered by the Power Cell.

- | | |
|---------------|------------|
| 4-20 Milliamp | Terminal 1 |
| 0-10 Volts DC | Terminal 3 |
| Analog Common | Terminal 2 |

120 VOLT SUPPLY

Terminals 5 and 6

GROUND

Terminal 4

TO ADJUST FULL SCALE

The Full Scale can be adjusted to match your motor with the Coarse and Fine Pots located under the Access Cover. Put your Ohm meter on the test points.

Convenient Scaling

- 5K Ohm = 5HP (This is the minimum setting)
 - 10K Ohm = 10HP
 - Etc.
 - 150K Ohm = 150HP (This is the maximum setting)
- (KW=HP x .746)

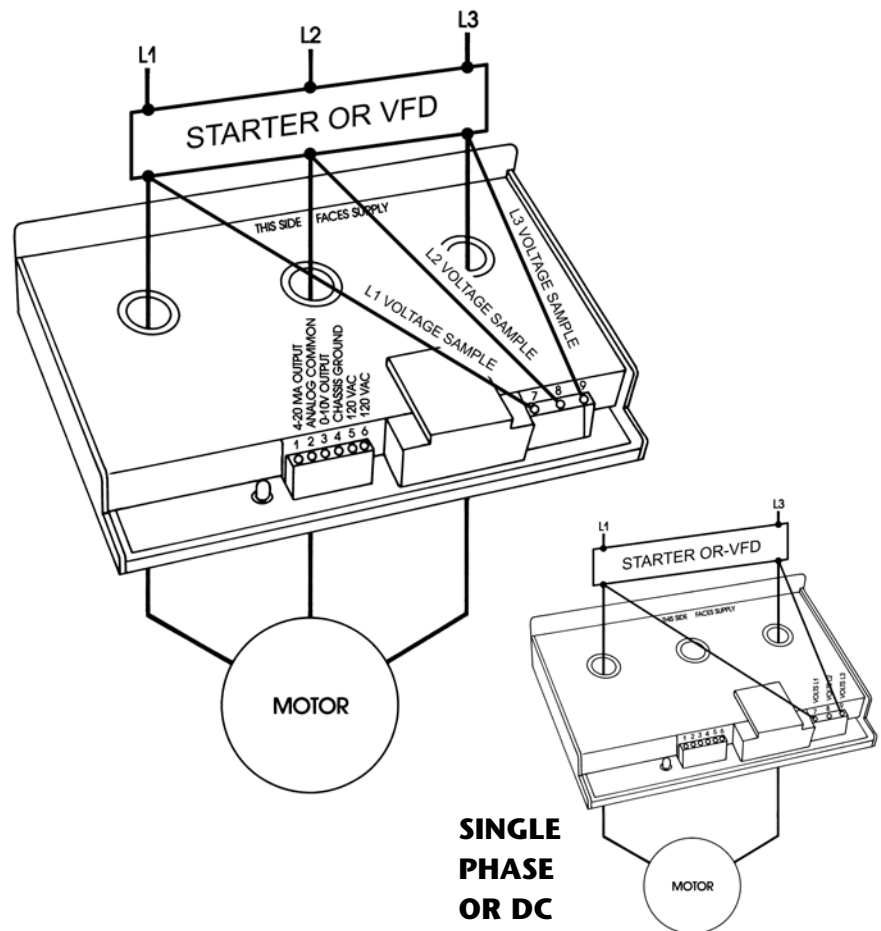

FOR SMALL MOTORS

Reduce the capacity by taking additional "Turns" through each hole for each phase (Mount the Power Cell on Standoffs). Example: 5HP Full Scale is reduced to 1HP with 5 Turns.

RESPONSE ADJUSTMENT

In some cases, the average power signal may be more useful than instantaneous power. The Response Adjustment slows the response of the Universal Power Cell. Pot is located under Access Cover. Clockwise is fastest.

SPECIFICATIONS

MODEL	UPC	UPC-230	UPC-FR	UPC-LB	UPC-KWH
ACCURACY	.5% Full Scale	*	*	*	*
FULL SCALE CAPACITY	5HP** to 150HP	*	*	5HP to 150HP Larger 0.9" holes	3 KW** to 100 KW
OUTPUTS	<ul style="list-style-type: none"> • 4-20 Milliamp, 500 Ohm Max Connected Impedance • 0-10 Volts DC 2000 Ohm Minimum Load 	*	*	*	<ul style="list-style-type: none"> • Relay: 30 Volts, 5 Milliamp max, 50 MS duration pulse • 0-10 Volts DC
RESPONSE ADJUSTABLE	• .5 Sec. to 12 Sec.	*	.050 Sec. to 1.2 Sec.	*	KWH, KWM, KWS
FREQUENCY	3HZ to 1KHZ	*	*	*	*
POWER CONSUMPTION	6 VA @ 120 Volts	3 VA @ 230 Volts	*	*	*

*Specifications same as UPC unless noted

**For smaller motors take extra "turns"

DIMENSIONS

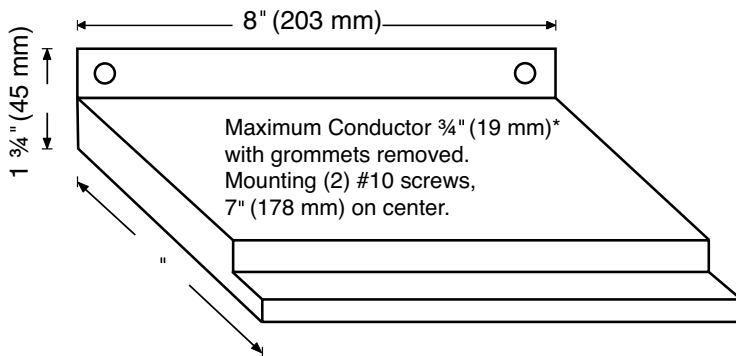

*UPC-LB larger 0.9" (23 mm) holes

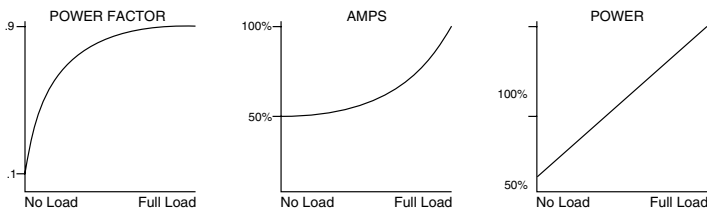

The Power Cell Uses Balanced Hall Effect Sensors

- Sensitive at low and high frequencies
- Fast Response
- Linear output
- Senses distorted waveforms
- Noise immune
- Accuracy is improved by eliminating the large phase shift errors from the CTs and PCs at low power factors

Balanced Hall Effect sensors are used to measure power with odd shapes and frequencies (like on a Variable Frequency Drive). A Hall Effect sensor has these two characteristics:

- It senses a magnetic field which is proportional to the current flowing through the conductor.
- The Hall Effect semiconductor can multiply two signals. Each Hall Effect Sensor is powered by the signal that comes from the voltage sample for that phase. The Hall device multiplies these voltage and current signals.

This is a vector multiplication which also calculates the lag of the current (power factor). The resulting output is then proportional to power (Volts x Amps x Power Factor).