

CR-150 CURRENT SENSING LOAD CONTROL INSTALLATION, SET UP AND ADJUSTMENT



The Model CR-150 monitors the current going to a motor. It has one adjustable trip point which can be either:

- High** - Relay switches when load is above the trip point.
- Low** - Relay switches when load is below the trip point.

MOUNTING

Wiring is done to un-pluggable terminal strips on the rear of the unit.

Three ways to mount:

- On door or raceway - use cutout template
- Panel Mount - use template + optional Bezel Kit (No Charge)
- On wall - on standard outdoor junction box + optional Outlet Box Adapter (No Charge)

FULL SCALE

The Range Finder Toroid has six current choices. Select one that is equal or larger than your load.

RANGE FINDER SWITCH	FULL SCALE	For Loads less than 5 AMPS take extra turns.
1	5 AMPS	EXAMPLE: $\frac{5 \text{ AMP Full Scale}}{5 \text{ Turns}} = 1 \text{ AMP Full Scale}$
2	10 AMPS	
3	25 AMPS	
4	50 AMPS	
5	100 AMPS	
6	150 AMPS	For Loads greater than 150 AMPS set Toroid for 5 AMPS and use External Current Transformer + Toroid

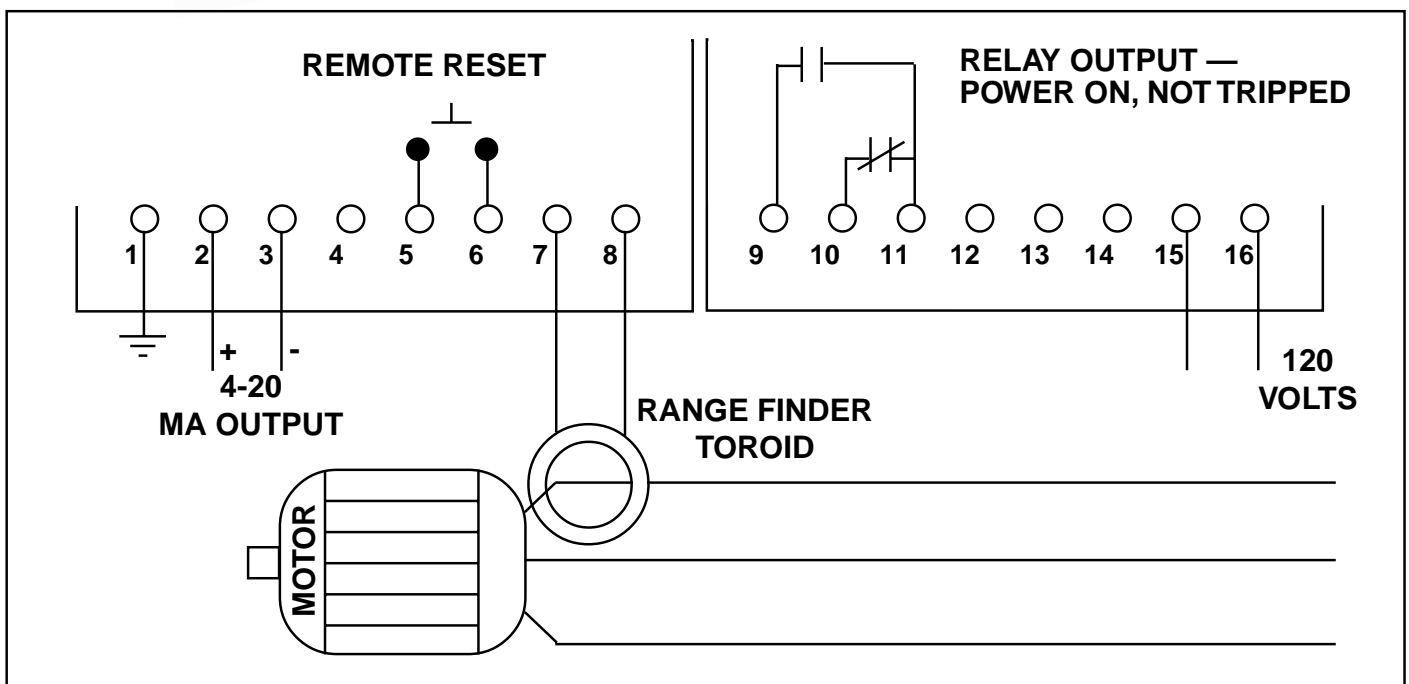

RANGE FINDER TOROID

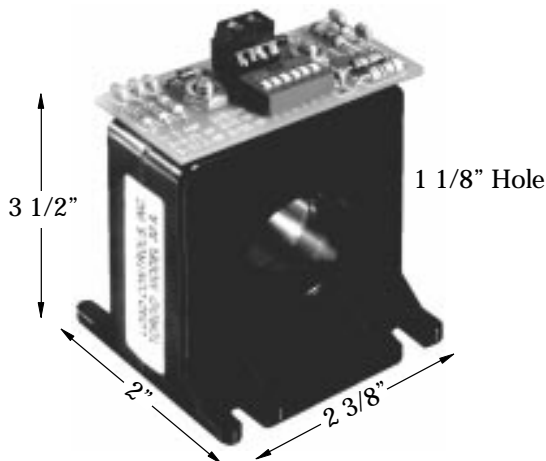

FOR MOTORS LESS THAN 5 AMPS

Take more "turns" of the leg through the Toroid. Each time the wire passes through the Toroid is a "turn".

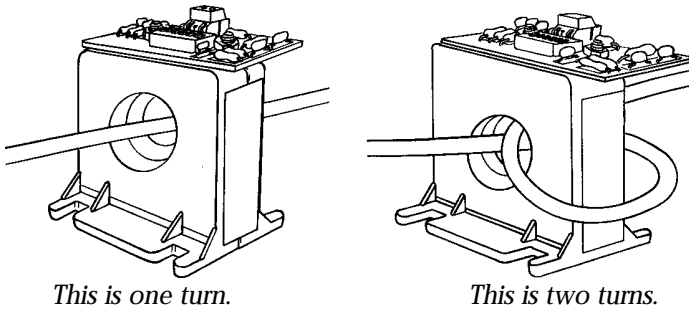

FOR MOTORS GREATER THAN 150 AMPS

A Current Transformer is used to reduce the primary current. The 5-amp secondary passes through the Toroid. Turn Dip Switch 1 on.

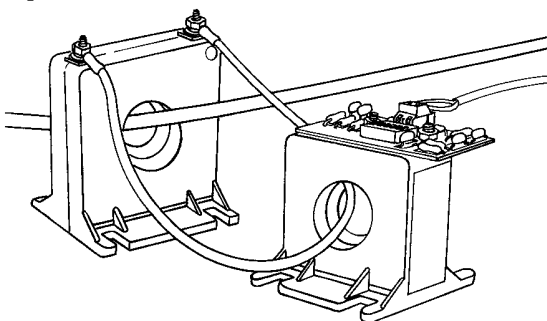

Pass secondary of CT through toroid.

CAUTION

When current is flowing through the primary of the external current transformer, always have a wire between the two brass Terminals on the CT.

If they are left open, dangerous and destructive voltages can develop.

HOOKING UP THE RESET

Control can be reset three ways:

- Manually with the Reset button on the control.
- Remotely with a remotely located reset button or relay.
- Automatic with a jumper.

Remote Reset-

Momentarily connect Terminal 5 to Terminal 6.

Automatic Reset-

Jumper Terminal 5 to Terminal 6.

The terminals for Reset generate a small amount of current (8-12 milliamps). To reset, you just need to connect the terminal to the circuit common (Terminal 6).

The switches or relays that you use must be suitable for low current (Gold flashed contacts, Reed Relays, Mercury Switches).

4-20 MILLIAMP ANALOG OUTPUT

The Analog Output is directly proportional to Full Scale capacity. It is always active. 500 ohm maximum connected impedance.

Terminal 2	4-20mA	Positive
Terminal 3	4-20mA	Negative

Use twisted pair or in noisy environments, use shielded cable. Ground shield at other end.

The Full Scale capacity to scale external meter, chart recorders or computers is the Dip Switch setting of the Toroid (or CT if one is used).

**THE CR-150 POWERS THE 4-20MA SIGNAL.
DON'T USE AN EXTERNAL DC POWER SUPPLY.**

SPECIFICATIONS CR-150

ENCLOSURE

Glass-filled Polycarbonate
NEMA 4, 4X - STYLE
(3 1/4" x 6 1/4" x 2")
(83 mm x 160 mm x 54 mm)

ANALOG OUTPUT

4-20mA; powered by the
CR-150 500 OHM
maximum connected
impedance

CAPACITY

150 AMPS directly
through Toroid
Large motors with external
Current Transformer & Toroid

RESPONSE TIME

50 Milliseconds

TEMPERATURE

0°C - 55°C

DIGITAL LOAD DISPLAY

.4" LED 3 Digit



TIMERS

Start-up and Trip Delay
0-90 second
0-2 second in .1 second
increments
2-90 second in 1 second
increments

RELAY OUTPUT

Form C 3 AMP @ 300 VAC or
1/8 HP @ 240 VAC
Latch when tripped

TO SET FULL SCALE

- Take Dip Switches of the Toroid (or CT if one is used), determine your Full Scale.
- Decide if you want to display AMPS or %.
- The  cycles through the choices shown below and blinks slowly for each choice. Each press of  moves you to the next choice.

TO DISPLAY % OF YOUR MOTOR FULL LOAD

To display % of your motor load requires 1 calculation.





$$\text{"RATIO"} = \frac{\text{Full Scale Capacity}}{\text{Your Motor Size}} \times 100$$









Enter this "Ratio" as Full Scale.

The Ratio must be greater than 100. If it isn't, change your hook-up to a higher capacity.

The display will now read 100% when your motor reaches its Full Load.



FRONT PANEL SET-UP TIPS

- 1) None of the settings will be changed until you hold down  and the fast blinking stops.
- 2) Five seconds after you have pressed a button, the Control will return to normal operation.
- 3) If you hold down the  digits will continue to change.

- 4) You only need to do  when you install the Control (or if you change the hook-up).

DIGITS [®]	DECIMAL [®]	DECIMAL [®]	DECIMAL [®]	AMPS [®]	%
	XXX.	XX.X	X.XX		
 to change	<i>if this is your choice, press</i>	<i>if this is your choice, press</i>	<i>if this is your choice, press</i>	<i>if this is your choice, press</i>	<i>if this is your choice, press</i>
-	-	-	-	-	-
					
<i>until fast blink stops</i>	<i>until fast blink stops</i>	<i>until fast blink stops</i>	<i>until fast blink stops</i>	<i>until fast blink stops</i>	<i>until fast blink stops</i>

TO VIEW AND CHANGE THE SET POINTS AND DELAY TIMES

 cycles through the choices. The LED for each choice will turn ON.

To change a setting, use 

Press ENTER until quick blinking stops to store your new choice.

After 5 seconds if you haven't pressed any buttons, control will return to normal operation.

For High Trip - Relay will switch when load is ABOVE the Set Point.

Press  until display shows HHH

Hold  until high LED stops blinking

For Low Trip - Relay will switch when load is BELOW the Set Point.

Press  until display shows LLL

Hold  until low LED stops blinking

The High or Low LED will remain on during normal operation.

Start-up Timer

The Start-up Timer bypasses the Control during motor start-up to avoid false trips because of current inrush. For convenience, the TIMING BEGINS WHEN THE MOTOR STARTS. The Start-up LED stays lit until the start-up period is over.

The start-up time should be:

- Long enough so that the load has stabilized.

To bypass Start-up Timer set time to zero seconds.

Delay Timers

To avoid nuisance trips from short overloads, Delay Timers bypass the Control for the selected time. The relays won't trip until the time is exceeded. If the trip condition goes away before the time is up, the timer resets to zero.

- Start with minimum Delay. If you are getting trips where you don't want them, increase the Delay Time.



**LOAD CONTROLS
INCORPORATED**

11/2001



VYDAS

Vydas International Marketing

Swan House Passfield Business Centre
Lynchborough Road Passfield

Hampshire GU30 7SB United Kingdom

Tel:44(0)1428 751822 Fax:44(0)1428 751833

Email:info@vydas.co.uk Web: www.vydas.co.uk