

# MICRA-M

6.1 PROCESS / LOAD CELL / TEMPERATURE

## DESCRIPTION

- The Micra-M, is a programmable instrument with the update technology, which accepts input signals for: Process (mA, V), Temperature (sensor Pt100, thermocouples J, K, T), or Load Cells (mV/V, mV).
- Colour display programmable, the Micra M let you choose between green, amber or red colour assignable to measure, programming or alarm activation.
- It provides excitation of 24V@60mA or 10V/5V@60mA.
- 10 point scaling for non-linear processes.
- Easily scaleable in engineering units required.
- Tare by front keyboard or remote control.
- 3 inputs with 12 logic functions programmable
- 2 brightness levels for display.
- Total or partial configuration lockout.
- Peak and Valley reading.
- Universal Power Supply 85-265 Vac MICRA-M or Low voltage supply 10,5-70 Vdc MICRA-M6.
- Communication protocol ASCII, ISO1745, MODBUS-RTU.
- Totally configurable from PC (Free Software).
- Programmable Filter (10 levels)
- Internal Resolution A/D  $\pm 15$  bits, Sigma-Delta Type.
- Segments Linearization (10 segments)



## STRUCTURE

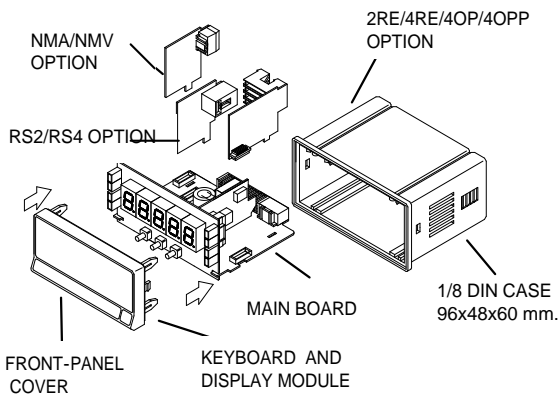

## DIMENSIONS AND MOUNTING

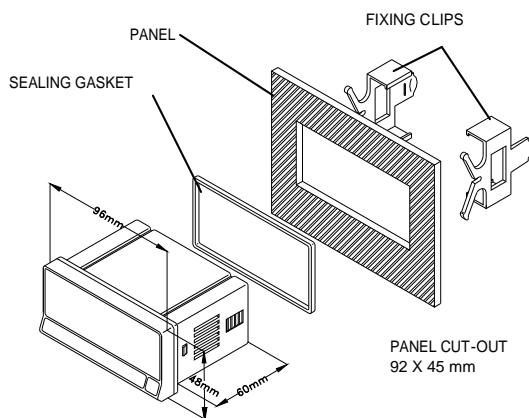

## CONNECTIONS

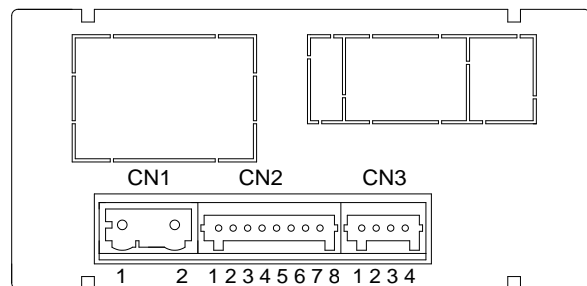

CN1	POWER SUPPLY			
PIN	AC VERSION	DC VERSION		
1	AC	VDC		
2	AC	VDC		
CN2	INPUT SIGNAL / EXCITATION			
	PROC.	TEMP.	LOAD CEL.	
1	-EXC24V		-EXC 10/5 V	
2	+EXC24V			
3			+EXC 10/5 V	
4		COM Pt100		
5	+mA			
6	+V			
7		Pt100	+TC	+mV
8	-V / -mA	Pt100	-TC	-mV
CN3	LOGICAL INPUT			
1	COMMON			
2	INPUT 1			
3	INPUT 2			
4	INPUT 3			



VYDAS

**Vydas International Marketing**  
 Swan House Passfield Business Centre  
 Lynchborough Road Passfield  
 Hampshire GU30 7SB United Kingdom  
 Tel:44(0)1428 751822 Fax:44(0)1428 751833  
 Email:[info@vydas.co.uk](mailto:info@vydas.co.uk) Web: [www.vydas.co.uk](http://www.vydas.co.uk)



# MICRA-M

## OPTIONS

The MICRA-M models can accept up to 3 simultaneous options; output option 2RE, 4RE, 4OPP or 4OP; communication option RS2 or RS4 and analogical option NMV or NMA:

- 2 SPDT Relays rating 8 A @ 250 V AC / 150 V DC  
Ref .....**2RE**
  - 4 SPST Relays rating 0.2 A @ 250 V AC / 50 V DC  
Ref .....**4RE**
  - 4 NPN Outputs rating 50 mA @ max. 50 V DC  
Ref .....**4OP**
  - 4 PNP Outputs rating 50 mA @ max. 50 V DC  
Ref .....**4OPP**
- The setpoints are independently programmable for HI / LOW action and time delay or hysteresis operation.

- RS232C communication output, 1200 to 19200 baud  
Ref .....**RS2**
  - RS485 communication output, 1200 to 19200 baud  
Ref .....**RS4**
- Serial communication protocols: standard, ISO1745 and MODBUS RTU.
- Isolated analogue output 4-20 mA  
Ref .....**NMA**
  - Isolated analogue output 0-10 V  
Ref .....**NMV**

## STANDARD FUNCTIONS

### • TARE

The tare operation is accomplished by a push of the TARE key on the front panel or by applying a low level signal to the corresponding logic input at the CN3 connector. The tare memory is cleared to zero by a constant push of 3 seconds of the TARE key (also at connector CN3).

### • PEAK AND VALLEY

The instrument detects and memorizes the max and min values reached for the variable after the last reset (peak and valley). To display the peak value, press the MAX/MIN key. The second push makes the display calls up the valley value (Also at connector CN3).

### • RESET PEAK AND VALLEY MEMORY

The peak and valley memories can be reset back to their default values by pressing the MAX/MIN key for 3 seconds; the reset value of these memories is the same as at the it. The same function is available at the CN3 connector.

### • HOLD

The hold function is only accessible from the CN3 connector. The hold condition (display frozen) is maintained as long as the corresponding logic input is kept at "0" level.

## FRONT-PANEL FUNCTIONS

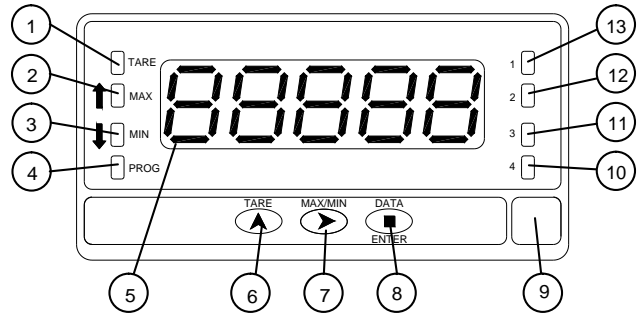

MODE		RUN	PROG
TARE	1	Indicates tare in the memory	-
MAX	2	Indicates peak displayed	-
MIN	3	Indicates valley displayed	-
PROG	4	-	Indicates programming mode
DISPLAY	5	Displays the input variable	Displays programming parameters
TARE KEY	6	Takes on the display value as tare	Increments the value of the flashing digit
MAX/MIN KEY	7	Recalls peak/valley values	Moves to the right
ENTER KEY	8	Enters in PROG mode. Displays data	Accepts data. Advances program
Label	9	Measurement unit	
LED Output 4	10	Activation Output 4	Programming output 4
LED Output 3	11	Activation Output 3	Programming output 3
LED Output 2	12	Activation Output 2	Programming output 2
LED Output 1	13	Activation Output 1	Programming output 1

## Logic Programmable Functions CN3

The rear connector CN3 provides 3 user programmable optocoupled inputs that can be operated from external contacts or logic levels supplied by an electronic system. Three different functions may be then added to the functions available from the front-panel keys. Each function is associated to one of the CN3 connector pins (PIN 2, PIN 3 and PIN 4) and is activated by applying a falling edge or a low level pulse to the corresponding pin with respect to common (PIN 1). Each pin can be assigned one of the 12 functions listed on the following pages.

(\*) Factory configuration.

Nº	Function	Description	Activation
0	No	Deactivated. the pin has no function.	None
1	TARE (*)	Adds the current display value to the tare memory. The display goes to zero.	Pulse
2	RESET TARE (*)	Adds the tare memory value contents to the display value and clears the tare memory.	Pulse
3	PEAK	Recalls peak value. A new falling edge returns to normal reading	Pulse
4	VALLEY	Recalls valley value. A new falling edge returns to normal reading	Pulse
5	RESET PEAK/VALLEY	Clears the PEAK or VALLEY memory (if the values are on display)	Pulse
6	HOLD (*)	Holds the display while the outputs remains active	Fixed level
7	PRINT	Send to the printer the display value	Pulse
8	PRINT GROSS	Send to the printer the display gross value (net + tare)	Pulse
9	PRINT TARE	Send to the printer the tare value	Pulse
10	SEND ASCII	Transmits the 4 last digits of the display to a MICRA-S. By holding the input to a low level sends every second.	Pulse Fixed level
11	CHANGE DISPLAY BRIGHTNESS	Select between two display brightness levels.	Fixed level
12	SHOW SETPOINT VALUE	Displays the selected setpoint value while the function is active	Fixed level

# MICRA-M

## SPECIAL FUNCTIONS

- Return to the factory configuration.
- Programmable color change display
- Total or partial lockout of the configuration by code.

## ACCURACY

- Temperature coefficient.....100ppm/°C
- Warm-up time..... 10 minutes

## FUSES (DIN 41661) Recommended (not incl.)

- MICRA-M .....F 0.2A/ 250V
- MICRA-M6 ..... F 2A/ 250V

## POWER SUPPLY

- UNIVERSAL..... 85 – 265 Vac  
100 – 300Vdc
- LOW VOLTAGE..... 10,5 – 70 Vdc  
22 – 53 Vac
- Consumption..... 5 W without options, 8 W max.

## A/D CONVERSION

- Technique..... Sigma-Delta
- Resolution..... ±15 bits
- Rate ..... 20/s

## FILTERS

Filter P (1 to 9)

- Cut-off frequency..... from 16 Hz to 0.67 Hz
- Slope..... 20 dB/decade

## DISPLAY

- Range..... -19999/ 19999
- Digits..... 5 LED of 14mm  
Programmable colour (Red, Green, Amber)
- LEDs..... 8, functions and outputs status
- Display refresh rate  
Process/Load cell ..... 20 /s  
Pt100 ..... 4 /s  
TC..... 10 /s
- Overflow indication ..... *-oUeR, oUeR*

## ENVIRONMENTAL

- Operating temperature ..... -10 °C to +60 °C
- Storage temperature ..... -25 °C to 80 °C
- Relative humidity..... <95% to 40 °C
- Max. Altitude.....2000 m

## MECHANICAL

- Dimensions ..... 1/8 DIN case, 96x48x60 mm
- Weight..... 160g
- Case material ..... UL 94 V-0 polycarbonate
- Sealed front panel ..... IP65 (indoor use)

## ORDERING REFERENCES

- Universal Power supply.....MICRA-M
- Low tension ..... MICRA-M6

## INPUT SIGNAL

Configuration ..... differential asymmetrical

PROCESS ..... VOLTAGE ..... CURRENT

- Input ..... ±10 V DC ..... ±20 mA DC
- Resolution ..... 1 mV ..... 1 µA
- Input impedance..... 1 MΩ..... 12,1Ω
- Excitation ..... 24 V @ 60 mA, 10 V/5 V @ 60 mA

LOAD CELL

- Input ..... ±15mV, ±30mV, ±150 mV
- Max. resolution..... 1 µV
- Input impedance..... 100 MΩ
- Excitation ..... 10 V @ 60 mA, 5 V @ 60 mA

POTENTIOMETER

- Display resolution ..... 0.005%
- Input impedance..... 1 MΩ
- Excitation ..... 10 V @ 60 mA

TEMPERATURE

- Cold junction compensation ..... -10°C to 60°C
- Pt100 sensor excitation ..... < 1 mA DC
- Max lead resistance ..... 40Ω /cable (balanced)
- Unit selectable ..... (Celsius) / (Fahrenheit)
- Resolution selectable..... 0.1° / 1°
- Offset programmable ..... ±9.9° / ±99°

## Input

## Temperature range

Thermocouple J (Fe-CuNi) .....	-50°C to +850°C -58°F to +1562°F
Thermocouple K (NiCr-NiAl) .....	-50°C to +1250°C -58°F to +2282°F
Thermocouple T (Cu-CuNi).....	-200°C to +400°C -328°F to +752°F
Pt100.....	-100°C to +800°C -148°F to +1472°F