

MICRA-D

FREQUENCY METER / TACHOMETER / COUNTER / CHRONOMETER

DESCRIPTION

- The MICRA-D model from the KOSMOS SERIE is a five-digit digital instrument with 2 programmable inputs that accept signals from a variety of standard sensors and pulse generators. Can be configured to work as:
 - TACHOMETER + TOTALIZER (8 digits)
 - TACHOMETER + DIRECTION OF ROTATION INDICATION
 - FREQUENCYMETER
 - COUNTER 5 digits + TOTALIZER (8 digits)
 - SEVERAL MODES OF COUNTER (UP, DOWN, UP/DOWN, PHASE)
 - CHRONOMETER (5 digits – 4 ranges)
- Colour of display programmable, the Micra-D let you choose between green, amber or red colour assignable to measure, programming or alarm activation.
- It provides excitation of 8V @ 30mA or 18 V @ 100mA.
- inputs with 13 logic functions programmable
- 2 brightness levels for display.
- Total or partial configuration lockout.
- Peak and Valley reading when TACHOMETER.
- Universal Power Supply 85-265 Vac MICRA-D or Low voltage supply 10,5-70 Vdc MICRA-D6.
- Communication protocols ASCII, ISO1745, MODBUS-RTU.



STRUCTURE

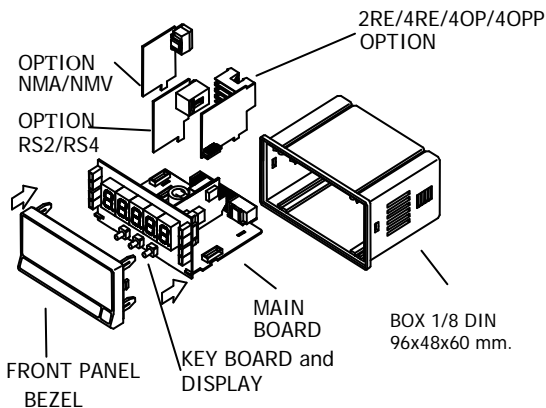

DIMENSIONS AND MOUNTING

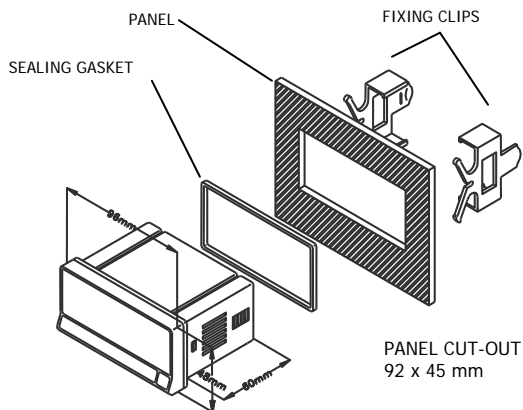

CONNECTIONS

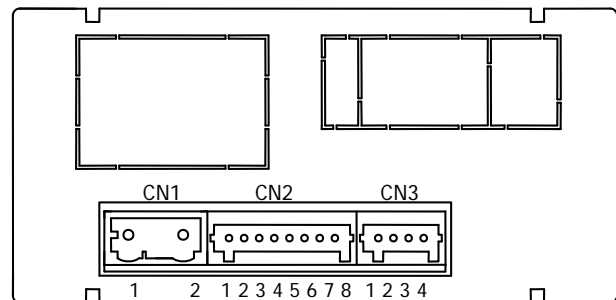

CN1	POWER SUPPLY	
	AC VERSION	DC VERSION
PIN		
1	AC	VDC
2	AC	VDC
CN2	INPUT SIGNAL /EXCITATION	
	1	Not Connected
	2	(+) 18 V Excitation
	3	(+) 8,2 V Excitation for Namur sensors
	4	(-) Common excitation / signal
	5	Signal B input
	6	Signal A input
	7	Not Connected
8	High voltage input (300 V ac max.)	
CN3	LOGIC FUNCTIONS	
	1	COMMON
	2	INPUT 1
	3	INPUT 2
4	INPUT 3	

MICRA-D

OPTIONS

The MICRA-D models can accept up to 3 simultaneous options; output option 2RE, 4RE, 4OPP or 4OP; communication option RS2 or RS4 and analogical option NMV or NMA:

- 2 SPDT Relays rating 8 A @ 250 V AC / 150 V DC
Ref..... **2RE**
 - 4 SPST Relays rating 5 A @ 250 V AC / 50 V DC
Ref..... **4RE**
 - 4 NPN Outputs rating 50 mA @ max. 50 V DC
Ref..... **4OP**
 - 4 PNP Outputs rating 50 mA @ max. 50 V DC
Ref..... **4OPP**
- The setpoints are independently programmable for HI / LOW action and time delay or hysteresis operation.*

- RS232C communication output, 1200 to 19200 baud
Ref..... **RS2**
 - RS485 communication output, 1200 to 19200 baud
Ref..... **RS4**
- Serial communication protocols: standard, ISO1745 and MODBUS RTU.
- Isolated analogue output 4-20 mA
Ref..... **NMA**
 - Isolated analogue output 0-10 V
Ref..... **NMV**

STANDARD FUNCTIONS

• OFFSET

The offset function operation is accomplished by a push on the OFFSET key on the front panel or by applying a low level signal to the corresponding logic input at the CN3 connector. The offset memory is cleared to zero by a constant push of 3 seconds on OFFSET key. (Also available at connector CN3).

OFFSET applies only on the PARTIAL counter.

If the OFFSET value is different from zero the TARE led will activate.

• PEAK AND VALLEY (FREQ./TACHOMETER MODE)

The instrument detects and memorizes the max and min values reached for the variable after the last reset (peak and valley).

To display the peak value, press the MAX/MIN key. The second push makes the display calls up the valley value (Also at connector CN3).

• RESET PEAK AND VALLEY MEMORY

The peak and valley memories can be reset back to their default values by pressing the MAX/MIN key for 3 seconds, taking into account that the reset value of these memories is the current value of the display when the reset is carried out. The same function is available at the CN3 connector.

• TOTALIZER

Totalizer with decimal point and programmable scale factor and independent from partial counter.

Count range : from 99999999 to -99999999.

Sensor type, mode and count direction are selected by the partial counter.

FRONT PANEL FUNCTIONS

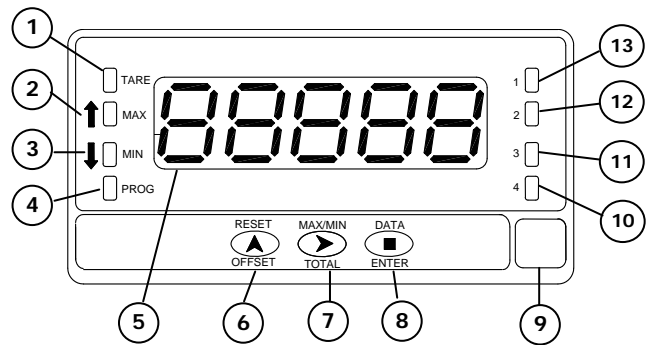

	MODE	RUN	PROG
TARA	1	Programmed Offset	-
MAX	2	Indicates peak on display (FREQ. / Tac.)	-
MIN	3	Indicates valley on display (FREQ. / Tac.)	-
PROG	4	-	PROG mode activated
DISPLAY	5	Displays the input variable	Displays programming parameters
RESET/ OFFSET KEY	6	Takes on the display value as offset	Increments the value of the flashing digit
MAX-MIN / TOTAL KEY	7	MAX, MIN or TOTAL visualisation	Moves to the right the flashing digit
ENTER KEY	8	Enters in PROG mode. Displays data	Accepts data. Advances program
Label	9	Measurement unit	
LED Output 4	10	Activation Output 4	Programming output 4
LED Output 3	11	Activation Output 3	Programming output 3
LED Output 2	12	Activation Output 2	Programming output 2
LED Output 1	13	Activation Output 1	Programming output 1



Vydas International Marketing
Swan House PBC Lynchborough Rd
Passfield Hampshire GU30 7SB UK

Tel: 44(0)1428 751822 Fax: 44(0)1428 751833

Email: info@vydas.co.uk Web: www.vydas.co.uk

Logic Programmable Functions CN3

The rear connector CN3 provides 3 user programmable optocoupled inputs that can be operated from external contacts or logic levels supplied by an electronic system. Three different functions may be then added to the functions available from the front-panel keys. Each function is associated to one of the CN3 connector pins (PIN 2, PIN 3 and PIN 4) and is activated by applying a falling edge or a low level pulse to the corresponding pin with respect to common (PIN 1). Each pin can be assigned one of the 13 functions listed hereafter.

(*) Factory configuration.

N°	Function	Description	Activation
0	Deactivated	None The pin has no function	None
1 (*)	OFFSET	Adds the current display value to the offset memory and sets the display to zero.	Falling edge
2 (*)	RESET	Sets to zero the partial counter value (Proc)	Falling edge
3	MAX	Displays the peak value. (MAX.) In Tachometer mode.	Low level
4	MIN	Displays the valley value. (MIN) In Tachometer mode.	Low level
5	RESET MAX/ MIN	Clears the peak or valley readings (the one shown in the display).	Falling edge
6 (*)	RESET TOTALIZER	Sets the TOTALIZER to zero.	Falling edge
7	PRINT PROCESS	Sends the partial counter value (Proc) to printer	Falling edge
8	PRINT TOTAL	Sends the total value to printer	Falling edge
9	PRINT OFFSET	Sends the offset value to printer	Falling edge
10	ASCII	Sends the last four digits to a MICRA-S. By holding the input to a low level, transmission takes place every second	Falling edge
11	BRIGHTNESS	Change the display brightness from Hi to Low	Low level
12	SETPOINT VALUE	Displays the selected setpoint value	Low level
13	FALSE SETPOINTS	Simulates that the instrument has a four setpoints option installed	Low level



MICRA-D

SPECIALS FUNCTIONS

- Return to the factory configuration.
- Change of display colour when the alarm is activated (programmable)
- Total or partial lockout of the configuration by code.

ACCURACY

Frequency/Tachometer 0,005%
Chronometer 0, 01%
Temperature coefficient 50 ppm/°C
Warm up time 5 minutes

FUSES (DIN 41661) Recommended (not supplied)

- MICRA-D F 0.2 A/250 V
- MICRA-D6 F 2 A/250 V

POWER SUPPLY

- UNIVERSAL 85 – 265 Vac
100 – 300Vdc
- LOW VOLTAGE 10,5 – 70 Vdc
22 – 53 Vac
- Consumption 5 W without options, 8 W max.

FILTERS

Antirebound
• Fc with duty cycle 50% 20 Hz
• Fc with duty cycle 30% 10 Hz

DISPLAY

Type 5 programmable tricolour 14 mm digits
LED's 8, control and status indication
Decimal Point programmable
Sign automatic s/configuration
Positive overflow indication OvEr
Negative overflow indication -OvEr

Counter display limits Process -99999 to 99999
Totalizer -9999999 to 99999999
Chronometer ranges 4, from 999.99s to 9999.9h
Frequency ranges ... 0.01 Hz to 20KHz/10KHz(totalizer)
Tachometer range 0 to 99999(rpm), programmable (rate)
Scale factor
Counter programmable from 0.0001 to 99999
Freq/Tach programmable from 0.0001 to 99999

Display update rate
Counter 100ms
Chronometer 100ms
Frequency/Tachometer programmable 0.1 to 9.9s

COUNTER and CHRONO MEMORY

Non-volatile E2PROM retains all programming data and count value when power is removed or interrupted.

INPUT SIGNAL

Frequency meter and Tachometer input

- Frequency Limits
- MIN frequency 0.01Hz
- MAX frequency without totalizer 19 KHz
- MAX frequency with totalizer 9.9 KHz

Counter input

- Up or down without relays 20 KHz
- Up or down with relays 15 KHz
- Bidirectionnal Phase or Direc without relays 20 KHz
- Bidirectionnal phase or Direc with relays 15 KHz
- Bidirectionnal Indep without relays 20 KHz
- Bidirectionnal Indep with relays 15 KHz

EXCITATION 8V/24V DC @ 30mA
18 Vdc (not stabilised) @ 100 mA

Contact closure

FILTER

- Fc with duty cycle 50% 20Hz
- Fc with duty cycle 30% 10Hz

INPUTS (2 CHANNELS)

MAGNETIC PICKUP

- Sensitivity Vin (AC) > 60mVpp @ F < 1 kHz
> 120 mVpp @ F > 1 kHz

NAMUR SENSOR

- Rc 3k3 Ω (incorporated)
- Ion < 1mA DC
- Ioff > 3mA DC

TTL/24V DC (encoder)

- Logic levels "0" < 2.4V DC, "1" > 2.6V DC

NPN or PNP sensor

- Rc 3k3 Ω (incorporated)
- Logic levels "0" < 2.4V DC, "1" > 2.6V DC

CONTACT CLOSURE

- Vc 5V
- Rc 3k9 Ω
- Fc (auto selection of input type prog.) 20Hz

HIGH VOLTAGE INPUT (1 CHANNEL)

- Voltage limits 10 to 300V AC

ENVIRONMENTAL

- Operating temperature -10 °C to +60 °C
- Storage temperature -25 °C to 80 °C
- Relative humidity <95% at 40 °C
- Sealed front panel IP65 (Indoor use)
- Max. Altitude 2000 m

MECHANICAL

- Dimensions 1/8 DIN 96 x 48 x 60 mm
- Weight 160 g
- Case material UL 94 V-0 polycarbonate

ORDER REFERENCES

- Universal supply MICRA-D
- Low voltage supply MICRA-D6



Vydas International Marketing
Swan House PBC Lynchborough Rd
Passfield Hampshire GU30 7SB UK

Tel: 44(0)1428 751822 Fax: 44(0)1428 751833

Email: info@vydas.co.uk Web: www.vydas.co.uk