



REPLACEMENT FOR

- GE/Yokogawa AB/DB40
- Weschler K231/241

BTW71P Programmable Tri-Color Bargraph

(Class III-Commercial/Industrial Grade)

A METEK Dixon “PRO” (PROgrammable) Series bargraphs are the preferred choice for new applications, or for replacement of switchboard meters, other common size indicators, and set point controllers. The “PRO” Series is feature-enhanced, and options are available to solve most common application problems. These models are easily configurable for maximum flexibility.

Application

AMETEK Dixon bargraphs are appropriate in any application where moving pointer meters have been used in the past, and in applications where greater accuracy, readability, and reliability are desirable. The BTW71P replaces all 4 1/2-inch standard switchboard circular meters and is a direct replacement for the GE/Yokogawa AB/DB40 and Westinghouse/Weschler K231/241 meters. This simplifies retrofit into existing systems without panel modifications. The instrument is suitable for local or remote, primary or redundant system indication.

Signal sensitivities span ANSI C39.1 ranges, all conventional current loops, and voltage control signals. A temperature measurement option makes the instrument a direct-reading indicator for E, J, K, and T thermocouples, or 100-ohm RTD, and an optional retransmission module simplifies distribution of the temperature parameter throughout the system. For control applications, an optional set point/relay module provides on/off and differential gap control and annunciation using three set points (LO, HI, and ALARM). An optional RS-422 serial data bus allows for distributed control system applications.

The bargraph’s color bar uses tri-color LEDs (red, amber, and green) to enhance visual resolution and readability. Standard models can be programmed to display up to five color zones. The color zones on models with the optional set point/relay module are determined by the set point placement: green for normal operation, amber for warning indications (LO or HI), and red for the ALARM indication.

The optional four-digit display reads to 10 percent over- and underrange. The colors of the digital display and annunciators do not change and should be specified at time of order (red, amber, or green).

User-programmability provides maximum versatility and minimizes the need for spares. A solid-state design with no moving parts yields a highly reliable product, especially under conditions of shock, vibration, dust and moisture. Features such as linearization, sensor power, retransmission, and min/max readings make the “PRO” Series the ideal choice for your application.

Features

- Brilliant tri-color LED display for excellent visibility
- Minimum 88,000-hour MTBF
- Rugged—high resistance to vibration and shock
- Microprocessor-based design
- Programmable configuration using front panel switches or a PC serial link
- Available with or without program switches on front
- Input signal ranges switch-selectable
- Auto-calibration algorithm
- Linearization of input signals
- Min/max signal memory (peak/valley hold)

- Underrange/overrange indication
- Modular design for flexibility and options

Options

- Digital display with true minus-sign indication
- On/off control using three set point relays
- Direct temperature measurement
- Auxiliary transducer power supply
- Two-wire, isolated retransmission
- RS-422 serial communication

BTW71P Specifications

Note: for ISA S67.04 and RP67.04 Part II, consult factory for models and assistance.

PHYSICAL CHARACTERISTICS

Number of bargraph segments 71
Resolution 1.0%

ENCLOSURE MATERIAL Non-glare black Noryl or ABS case complying with UL94 V-0 or V-1

DIGITAL DISPLAY OPTION (True minus sign) -9999 to 9999
Number of digital display digits 4
Resolution 0.01% ± 1 count*

ENVIRONMENTAL CHARACTERISTICS

Operating temperature range (MIL-E16400G, Class 4) 0 to +60° C
Storage temperature range -40 to +85° C

POWER REQUIREMENTS Either 115/230 VAC at 50, 60, 400 Hz
Line regulation ±10%
Power consumption (typical, depends upon options) 8.0 VA

SENSITIVITY RANGES (Reference ANSI C39.1 Std. Sensitivities)

STANDARD FULL SCALE INPUTS FROM ZERO
(DIP-switch selectable):
DC currents 500 µA to 50 mA
DC voltages 1 to 250 V

OPTIONAL FULL SCALE INPUTS FROM ZERO
DC currents - factory configured 50 µA to 250 mA
Plug-in modules:
RS-422 Serial Data Comm.
DC voltages 50 to <1000 mV
AC currents 1 to 1000 mA; 5 A
AC voltages 250 mV to 250 V
Thermocouple - Type E -100 to +1000° C
Thermocouple - Type J -18 to +760° C
Thermocouple - Type K -18 to +1370° C
Thermocouple - Type T -160 to +400° C
RTD (100-ohm platinum) -200 to +850° C

DC INPUT PARAMETERS

Linearity 0.02% of span ± 1 count*
Accuracy 0.04% of span ± 1 count*†
Zero stability <0.01% per °C
Gain stability <0.02% per °C
Input impedance:
For voltage inputs >200 k ohms
For 4 to 20 mA DC current inputs 100-ohm compliance resistor
For 10 to 50 mA DC current inputs 40-ohm compliance resistor
For all other current inputs Consult factory
Response time (typical) 175 ms
Overload (signal) 200% or 250 VDC maximum

AC INPUT PARAMETERS (true RMS-reading)

Linearity 0.4% of span **
Accuracy 0.5% of span **
Zero stability <0.04% per °C
Gain stability <0.04% per °C
Input impedance for voltage inputs >200 k ohms
Response time (typical) 325 ms
Overload (signal) 200% or 250 VAC maximum

SET POINT OPTION (internal module)

Standard set points LO and HI
Configurable alarm HI/HI (default) or LO/LO
Setability 0.1%
Hysteresis 1.0%
Relay response time (typical):
For DC inputs 350 ms
For AC inputs 650 ms
Relay contact ratings (three Form C): 0.4 A at 125 VAC
2 A at 30 VDC

RETRANSMISSION ACCURACY (4 to 20 mA)

± 0.1%

LINEARIZATION

8th-order polynomial (nine terms). Refer to "PRO" Series Interface Kit.

* 1 count is defined as a ± unit value change of the right-most digit.

† Call factory for thermocouple, RTD, and square root input accuracy information.

** Except for first 5% of span.

BTW71P Dimensions

Dimensions given in inches
(metric in parentheses)

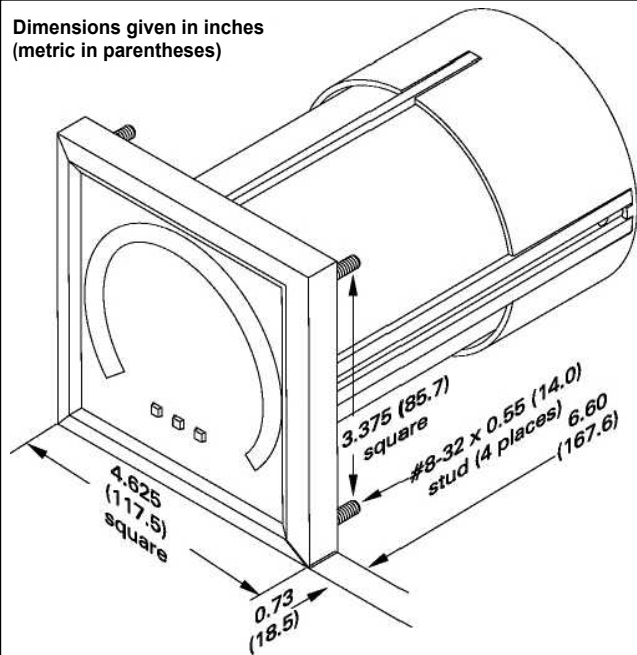

Artwork Guidelines

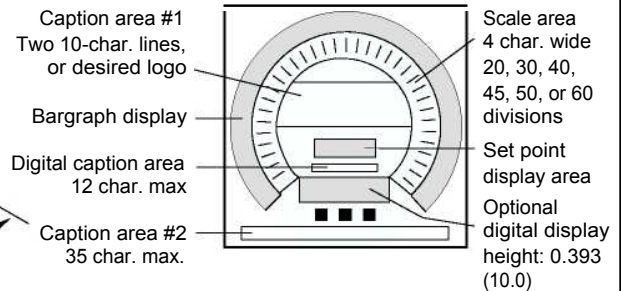

Panel Cutout Dimensions

