

# Digital Panel Meters Modular signal conditioner Type USC-DIN



- Linearization of V and A inputs up to 16 points

- Multi-input modular signal's conditioner
- 0.1% RDG basic accuracy
- TRMS AC current and voltage measurements
- AC/DC current measurements; selectable full scales (200µA to 5A)
- AC/DC voltage measurements; selectable full scales (200mV to 500V)
- °C or °F temperature measurements (Pt100-250-500-1000, Ni100, TC J-K-S-T-E)
- Resistance measurements; selectable full scales (20Ω to 20kΩ)
- Up to 4 independent alarm set-points (optional)
- 20mA/10VDC analog output (optional)
- Serial port RS485 or RS232 (optional)
- MODBUS, JBUS communication protocol
- Front protection degree: IP 20

## Product Description

µp-based signal's conditioner, for current, voltage, temperature and resistance measurements. Measuring ranges and functions easily programmable from the PC by means of optional UscSoft software available on

request. UscSoft includes programming, display and min-max functions. Conditioner's housing for DIN-RAIL mounting with front protection degree: IP 20. All displaying and programming data are referred to UscSoft.

## How to order

**USC XXX XX XX XX X XX**

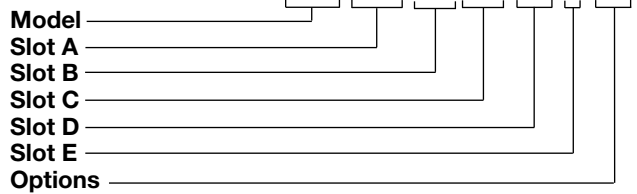

## How to order

**UscSoft-kit**

UscSoft-kit: software plus "UCOM1" communication cable for programming USC by means of PC.

## Type Selection

Slot A (measuring inputs)	Slot B (communication)	Slot C (communication and alarm)	Slot D (communication)
<b>LSX:</b> single channel input: 0.2-2-20mA DC/AC, 0.2-2-20V DC/AC  <b>LSE/ LSF:</b> single + AUX input : 0.2-2-20mA DC/AC; 0.2-2-20V DC/AC  <b>HSX:</b> single channel input: 0.2-2-5A DC/AC; 20-200-500V DC/AC  <b>TRX:</b> signal input: TC tem- perature probes: J-K-S- T-E, Pt100-250-500- 1000 and resistance 0.02-0.2-2-20kΩ	<b>XX:</b> None <b>SX:</b> Serial port RS485 <b>SY:</b> Serial port RS232  <b>Options</b>  <b>XX:</b> None <b>TX:</b> Tropicalization	<b>XX:</b> None <b>R1:</b> Single relay output, (AC1-8AAC, 250VAC) <b>R2:</b> Dual relay output, (AC1-8AAC, 250VAC) <b>R4:</b> Dual relay output, (AC1-8AAC, 250VAC) + dual open collector out- put (NPN, 100mA) <b>R5:</b> 4 Relay outputs (AC1- 5AAC, 250VAC) <b>AV(*):</b> Single analogue out- put: 0 to 20mA DC and 0 to 10V DC	<b>XX:</b> None <b>AV(*):</b> Single analogue out- put, 0 to 20mA DC and 0 to 10V DC  <b>(*):</b> The two analogue outputs cannot be used at the same time. It is possible to plug in only one module by signal conditioner.  <b>Slot E (power supply)</b>  <b>H:</b> 90 to 260V AC/DC <b>L:</b> 18 to 60V AC/DC



## USC architecture

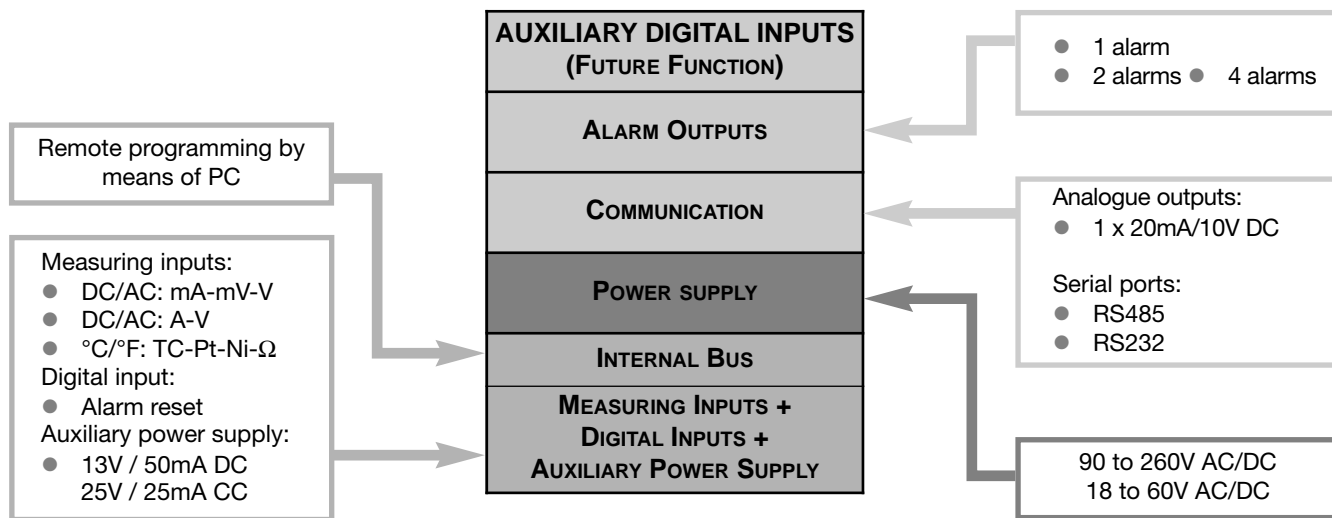

## Input Specifications

<b>Analogue inputs</b> BQ LSX module BQ LSE/LSF module BQ HSX module BQ TRX module BQ TRX module	Measuring module 1, mA and V DC/AC 1, mA and V DC/AC + AUX 1, A and V DC/AC 1, temperature 1, resistance	<b>Measurements</b>  Coupling Crest factor  <b>Input impedance</b>  <b>Frequency</b>  <b>Overload</b>  <b>Compensation</b>  RTD         TC	and max min indications” Current, voltage, temperature and resistance. For the current and voltage measurements: TRMS measurement of distorted sine waves. Direct. $\leq 3$ ; $A_{Pmax}=1,7I_n$ ; $V_{Pmax}=1,7U_n$  See table “input impedances and overloads”  40 to 440 Hz  See table “input impedances and overloads”  Only temperature measurement module. - For Pt 100-250-500-1000, 3-wire connection: up to 10Ω - For resistance measur. with 20Ω range: up to max 0.1Ω - For resistance measurements with $\geq 200\Omega$ range: up to max 10Ω Internal cold junction, within temperature range from 0 to +50°C. Automatic or manual compensation from 0 to 50°C.
<b>Digital inputs (CMD)</b> Number of inputs Use Contact reading signal	Incl. in the measuring module 1 (voltage-free) Reset of latch alarms BQ xxx: <0.1mA, <3.5V DC BQ LSE/LSF: <2.5mA, <14V DC Max 1kΩ Min 500kΩ Non-insulated		
Close contact resistance Open contact resistance Insulation	Max 1kΩ Min 500kΩ Non-insulated		
<b>Accuracy (RS485)</b>	See table “Measuring accuracy”, temperature drifts and minimum-maximum indications”		
<b>Additional errors</b> Humidity Input frequency Magnetic field	0.3% RDG, 60% to 90% R.H. 0.4% RDG, 62 to 440 Hz 0.5% RDG @ 400 A/m		
<b>Temperature drift</b>	See table “Measuring accuracy, temperature drifts and maximum minimum indications”		
<b>Sampling rate</b> BQ LSX module BQ LSE/LSF module BQ HSX module BQ TRX module	500 samples/s @ 50Hz 500 samples/s @ 50Hz 500 samples/s @ 50Hz 500 samples/s @ 50Hz		
<b>Measurement updating</b>	200 msec @ 50 Hz		
<b>Resolution of measurements</b>	10.000 points (4-dgt)		
<b>Max. and min. indications</b>	See table “Measurement accuracy, temperature drifts		

## Measurement accuracy, temp. drifts, max and min indications

All accuracies and min/max indications are referred to an ambient temp. range of 25°C ±5°C, rel. humidity ≤60% and scale ratio (electrical/displayed scale) equal to 1. The conversion into °F is obtained acting on the electrical/displayed scale ratio.

Module	Inputs	Type	Accuracy	Temp. drift	Min. indication (■)	Max. indicat. (■)
BQ LSX/ BQ LSE/ BQ LSF	-200µA to +200µA -2mA to +2mA -20mA to +20mA -200mV to +200mV -2V to +2V -20V to +20V	DC/AC	DC: ±(0.1%RDG+3DGT) 0% to 25% FS; ±(0.1%RDG+2DGT) 25% to 110% FS. TRMS (45 to 65Hz)*: ±(0.3%RDG+3DGT) 0% to 25% FS; ±(0.3%RDG+2DGT) 25% to 110% FS.	±150 ppm/°C	- 200.0 - 2.000 - 20.00 - 200.0 - 2.000 - 20.00	+ 200.0 + 2.000 + 20.00 + 200.0 + 2.000 + 20.00
BQ HSX	-200mA to +200mA -2A to +2A -5A to +5A -20V to +20V -200V to +200V -500V to +500V	DC/AC	DC: ±(0.1%RDG+3DGT) 0% to 25% FS; ±(0.1%RDG+2DGT) 25% to 110% FS. TRMS (45 to 65Hz)*: ±(0.3%RDG+3DGT) 0% to 25% FS; ±(0.3%RDG+2DGT) 25% to 110% FS.	±150 ppm/°C	- 200.0 - 2.000 - 5.000 - 20.00 - 200.0 - 500.0	+ 200.0 + 2.000 + 5.000 + 20.00 + 200.0 + 500.0
BQ TRX Thermo- couple	-50°C to +760°C -58 °F to +1400 °F -200°C to +1260°C -328 °F to +2300°F -200°C to +1000°C -328°F to +1832°F -50°C to +1750°C -58°F to +3182°F -200°C to +400°C -328°F to +752°F	J J K K E E S S T T	±(0.2%RDG+1DGT) ±(0.2%RDG+2DGT) ±(0.2%RDG+2DGT) ±(0.2%RDG+4DGT) ±(0.2%RDG+2DGT) ±(0.2%RDG+4DGT) ±(0.2%RDG+2DGT) ±(0.2%RDG+4DGT) ±(0.2%RDG+2DGT) ±(0.2%RDG+4DGT)	±150 ppm/°C	- 50°C - 58°F - 200°C - 328°F - 200°C - 328°F - 50°C - 58°F - 200°C - 328°F	+ 760°C + 1400°F + 1260°C + 2300°F + 100°C + 1832°F + 1750°C + 3182°F + 400°C + 752°F
BQ TRX Thermo- resis- tance	-200°C to +850°C -328°F to +1562°F -200.0°C to +200.0°C -328°F to +392°F -200.0°C to +200.0°C -328°F to +392°F -200.0°C to +200.0°C -328°F to +392°F -200.0°C to +200.0°C -328°F to +392°F -60°C to +180°C -76°F to +356°F	Pt100 Pt100 Pt100 Pt100 Pt250 Pt250 Pt500 Pt500 Pt1000 Pt1000 Ni100 Ni100	±(0.2%RDG +2DGT) ±(0.2%RDG +4DGT) ±(0.5%RDG +5DGT) ±(0.5%RDG +5DGT) ±(0.5%RDG +5DGT) ±(0.5%RDG +5DGT) ±(0.5%RDG +5DGT) ±(0.5%RDG +5DGT) ±(0.5%RDG +5DGT) ±(0.5%RDG +5DGT) ±(0.5%RDG +1DGT) ±(0.5%RDG +2DGT)	±150 ppm/°C	- 200 - 328 - 200.0 - 328 - 200.0 - 328 - 200.0 - 328 - 200.0 - 328 - 60 - 76	+ 850 + 1562 + 200.0 + 392 + 200.0 + 392 + 200.0 + 392 + 200.0 + 392 + 180 + 356
BQ TRX Resis- tance	0 to 20Ω 0 to 200Ω 0 to 2000Ω 0 to 20.00kΩ	Ω	±(0.2%RDG+2DGT) 25% to 110% FS ±(0.2%RDG+3DGT) 0% to 25% FS	±150 ppm/°C	0 0 0 0	20.00 (■) 200.0 (■) 2000 (■) 20.00 (■)

(\*) <45Hz, >65Hz: ±(0.5%RDG+3DGT) 0% to 25% FS; ±(0.5%RDG+2DGT) 25% to 110% FS.

(■) The min. indication for TRMS measurement (AC or DC) is 0; it is possible to modify the decimal point position.



## Input impedances and overloads

Module	Inputs	Type	Impedance	Overload (continuous)	Overload (1s)
BQ LSX/ BQ LSE/ BQ LSF	-200µA to +200µA	AC/DC	≤2.2kΩ	5mA	10mA
	-2mA to +2mA	AC/DC	≤22Ω	50mA	150mA
	-20mA to +20mA	AC/DC	≤22Ω	50mA	150mA
	-200mV to +200mV	AC/DC	≥2.2kΩ	10V	20V
	-2V to +2V	AC/DC	≥200kΩ	50V	100V
	-20V to +20V	AC/DC	≥200kΩ	50V	100V
BQ HSX	-200mA to +200mA	AC/DC	≤1Ω	0.8A	1A
	-2A to +2A	AC/DC	≤0.012Ω	7.5A	100A
	-5A to +5A	AC/DC	≤0.012Ω	7.5A	100A
	-20V to +20V	AC/DC	≥2MΩ	750V	1000V
	-200V to +200V	AC/DC	≥2MΩ	750V	1000V
	-500V to +500V	AC/DC	≥2MΩ	750V	1000V
BQ TRX Thermo- couple	-50°C to +760°C	J	I <sub>LK</sub> < 0.5µA	Max 5V	Max 10V
	-58 °F to +1400 °F	J			
	-200°C to +1260°C	K			
	-328 °F to +2300°F	K			
	-200°C to +1000°C	E			
	-328°F to +1832°F	E			
	-50°C to +1750°C	S			
	-58°F to +3182°F	S			
BQ TRX Thermoresis- tance	-200°C to +850°C	Pt100	800µA (*)	Max 5V	Max 10V
	-328°F to +1562°F	Pt100	800µA (*)		
	-200,0°C to +200,0°C	Pt250/Pt100	90µA (*)		
	-328°F to +392°F	Pt250/Pt100	90µA (*)		
	-200,0°C to +200,0°C	Pt1000/Pt500	800µA (*)		
	-328°F to +392°F	Pt1000/Pt500	800µA (*)		
	-60°C to +180°C	Ni100	800µA (*)		
	-76°F to +356°F	Ni100	800µA (*)		
BQ TRX Resistance	0 to 20Ω	Ω	800µA (*)	Max 5V	Max 10V
	0 to 200Ω		90µA (*)		
	0 to 2000Ω		800µA (*)		
	0 to 20.00kΩ		90µA (*)		

## Output specifications

RS422/RS485	Serial output	<b>(on request)</b> Module: BR SX Bidirectional (static and dynamic variables). Display of data reception/transmission Multidrop, 2 or 4 wires, 1000m Directly on the module by means of jumper 1 to 255, selectable by means of software MODBUS RTU/JBUS Measurement, min value max value alarm status All programming parameters, min max reset	Data format	8 data bit, no parity, 1 stop bit selectable 4800, 9600, 19200 and 38400 bit/s By means of opto-couplers 4000 V <sub>rms</sub> output to measuring inputs 4000 V <sub>rms</sub> output to power supply input
	LED		Baud rate	
	Connections		Insulation	
	Distance			
	Terminalization			
	Addresses			
Protocol Data (bidirectional) Dynamic (reading only)	Static (reading/writing)		RS232	<b>(on request)</b> Module: BR SY Bidirectional (static and dynamic variables) 3 wires, max. 15m 1 start bit, 8 data bit, no parity, 1 stop bit selectable 4800, 9600, 19200 and 38400 bit/s As per RS422/485
			Serial output	
			Connections	
			Distance	
			Data format	
Baud rate				
Other characteristics				

(\*) Max. generated measuring current for resistance equal to 0Ω

## Output characteristics (continuous)

<b>Alarm output</b> Alarm type	<b>(on request)</b> Over-range alarm, up alarm, down alarm, down alarm with start-up deactivation, up alarm with latch, down alarm with latch	Open collector output	NPN transistor type V <sub>ON</sub> 1.2 VDC/ max. 100 mA V <sub>OFF</sub> 30 VDC max.
Alarm set-point	Adjustable from 0 to 100% of displayed electric range	Insulation	By means of opto-couplers 4000 V <sub>RMS</sub> output to measuring input 4000 V <sub>RMS</sub> output to power supply input
Hysteresis	0 to 100% of displayed range	<b>Single analogue output</b>	<b>(on request)</b> Module: BO AV
On-time delay	0 to 255 s	Range	0 to 20 mADC, 0 to 10 VDC
Off-time delay	0 to 255 s	Scaling factor	Programmable within the entire retransmission range; allows to manage the retransmission of all the values from
Output status	Selectable: normally energized /de-energized		0 to 20 mA / 0 to 10V
Min response time	500 ms, with filter excluded, without alarm activation delay	Accuracy	± 0.2% FS (@ 25°C ± 5°C)
Output channels	1 with module BO R1 (relay output). 2, independent with module BO R2 (2 relay outputs). 4, independent with module BO R4 (2 relay outputs + 2 open collector outputs). BO R5 (4 relay outputs).	Response time	≤ 10 ms
BO R1, R2, R4 relay outputs	Type SPDT AC 1: 8A, 250VAC DC 12: 5A, 24VDC AC 15: 2.5A, 250VAC DC 13: 2.5A, 24VDC	Temperature drift	± 200 ppm/°C
BO R5 relay output	Type SPST (NO) AC 1: 5A, 250VAC DC 12: 3A, 24VDC AC 15: 1.5A, 250VAC DC 13: 1.5A, 24VDC	Load: 20 mA output 10 V output	≤ 700 Ω ≥ 10 kΩ
Insulation	4000 V <sub>RMS</sub> output to measuring input, 4000 V <sub>RMS</sub> output to power supply input.	Insulation	By means of opto-couplers 4000V <sub>rms</sub> output to measuring input 4000V <sub>rms</sub> output to power supply input
		Notes:	The two outputs cannot be used at the same time.
		<b>Excitation output</b>	<b>(on request)</b>
		BQ LSE Module	
		Voltage	13 VDC ±10% max. 50 mA
		BQ LSF Module	
		Voltage	25 VDC ±10% max. 25 mA
		Insulation	25V <sub>rms</sub> output to measuring input 4000 V <sub>rms</sub> output to power supply input

## Software functions

<b>Min / Max storage</b>	Automatic storage (in the EEPROM) of the minimum and maximum measured value from the previous memory reset	Electrical range	displayed scale compression/expansion (max. 2 without filter, up to 10 with filter)
<b>Measurement selection</b>	Depending on the module: measuring range and type of probe (resistance, RTD thermoresistance, TC thermocouple) or measuring type (TRMS or DC).	Decimal point position	Programmable within the whole measuring range
<b>Integration time selection</b>	Automatic or from 100.0 to 999.9 ms only in the current and voltage measurement.	Displayed range of the variable	Programmable within the display range
<b>Scaling factors</b> Operating mode	Electrical scale compression,	<b>Diagnostics (only with Usc Soft)</b>	The display flashes when the limits of the display range are exceeded and the data are updated up to 20% of the rated display range.
		Burn-out:	Only temperature inputs



## Software functions (continuous)

TC	Opening of probe's connection: EEE indication	<b>Linearization</b> Points Input range  Output range	Up to 16 Selectable by every single point Selectable by every single point
RTD	Opening of probe's connection: EEE indication probe's short circuit: -EEE indication.		
<b>Digital filter</b> Filter operating range Filtering coefficient	0 to 9999 1 to 32	<b>UscSoft</b>	Software for programming USC by means of PC (Windows 95, 98se, ME, XP) by means of serial port RS485 and relevant connection cable. UscSoft includes programming, displaying, min-max storage functions. The software is available in English, Spanish, Italian, German and French. See also "The programming of USC by means of PC".
<b>Scaling</b>	Selection of min value of the input range. Selection of max value of the input range. Selection of decimal point position. Selection of min display value. Selection of max display value.		

## General Specifications

<b>Operating temperature</b>	0° to 50°C (32° to 122°F) (H.R. < 90% non-condensing)	<b>Safety Standards</b> Safety	EN 61010-1, IEC 61010-1
<b>Storage temperature</b>	-10° to 60°C (14° to 140°F) (H.R. < 90% non-condensing)	<b>Connections</b> Wire section	Screw type Max 2.5mm <sup>2</sup>
<b>Insulation reference voltage</b>	300 V <sub>RMS</sub> to ground (500V input)	<b>Housing</b> Dimensions Material	44 x 113 x 107 mm PC-ABS, self-extinguishing: UL 94 V-0
<b>Insulation</b>	See table "Insulation between inputs and outputs"	<b>Protection degree</b>	IP20
<b>Dielectric strength</b>	4000 V <sub>RMS</sub> for 1 minute	<b>Weight</b>	560 g approx (included all modules and packing)
<b>Rejection</b> NMRR CMRR	40 dB, 40 to 60 Hz 100 dB, 40 to 60 Hz	<b>Approvals</b>	CE, UR, CSA
<b>EMC</b>	EN61000-6-2, IEC61000-6-2 EN61000-6-3, IEC61000-6-3		

## Supply Specifications

<b>AC/DC voltage</b>	90 to 260V (standard) 18 to 60V (on request)	<b>Energy consumption</b>	≤ 30VA/12W (90 to 260V) ≤ 20VA/12W (18 to 60V)
----------------------	---	---------------------------	---

### Excitation output

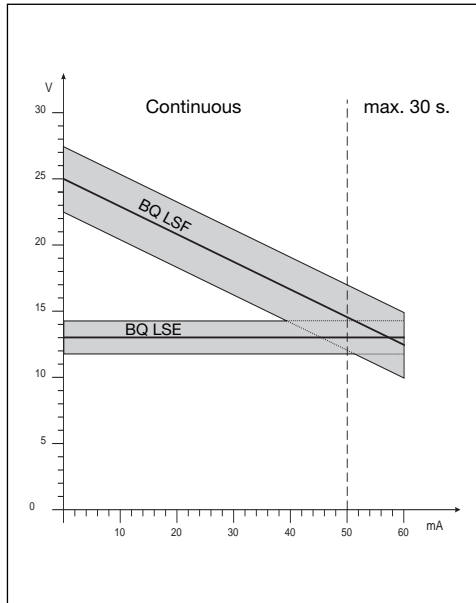

### Insulation between inputs and outputs

	Meas. inputs	Relay output	Static output	Analogue output	Serial Port	AUX p.supply	90-260VAC/DC p.supply	18-60VAC/DC p.supply
Meas. inputs	-	4kV	4kV	4kV	4kV	25V	4kV	4kV
Relay Output	4kV	-	2kV	4kV	4kV	4kV	4kV	4kV
Static Output	4kV	2kV	-	4kV	4kV	4kV	4kV	4kV
Analogue Output	4kV	4kV	4kV	-	4kV	4kV	4kV	4kV
Serial Port	4kV	4kV	4kV	4kV	-	4kV	4kV	4kV
AUX p.supply	25V	4kV	4kV	4kV	4kV	-	4kV	4kV
90/260VAC/DC p. supply	4kV	4kV	4kV	4kV	4kV	4kV	-	-
18-60VAC/DC p. supply	4kV	4kV	4kV	4kV	4kV	4kV	-	-

### Available modules

Type	N. of channels	Ordering code
USC main unit		BD XX
DC/AC input: 200µA , 2mA, 20mA, 200mV, 2V, 20V	1	BQ LSX
DC/AC input: 200µA , 2mA, 20mA, 200mV, 2V, 20V + excitation output	1	BQ LSE/ BQ LSF
DC/AC input: 200mA, 2A, 5A, 20V, 200V, 500V	1	BQ HSX
Input: 20Ω, 200Ω, 2kΩ, 20kΩ	1	BQ TRX
TC: J-K-S-T-E, Pt100-250-500-1000, Ni100	1	BQ TRX
Analogue output 0 to 20mA, 0 to 10V	1	BO AV
Relay output	1	BO R1
Relay output	2	BO R2
Outputs: 2 relays + 2 open collectors	4	BO R4
Relay output	4	BO R5
RS485 Serial Port	1	BR SX
RS232 Serial Port	1	BR SY
Power supply 18 to 60V AC/DC		BP L
Power supply 90 to 260V AC/DC		BP H

### Possible module combinations

Basic Unit	Slot				
	A	B	C	D	E
Measuring inputs: LSX, LSE, LSF, HSX, TRX	●				
RS485 serial port: SX		●			
RS232 serial port: SY		●			
Analogue output: AV (*)			●	●	
Relay outputs and/or open collector: R1, R2, R4, R5			●		
Power supply: H, L					●

(\*) Up to 1 module max.

### Used calculation formulas

Only for TRMS Measurements

Instantaneous effective voltage (TRMS) 
$$V_1 = \sqrt{\frac{1}{n} \cdot \sum_1^n (V_1)_i^2}$$

Instantaneous effective current (TRMS) 
$$A_1 = \sqrt{\frac{1}{n} \cdot \sum_1^n (A_1)_i^2}$$

# Wiring diagrams

## Process signal wiring diagrams

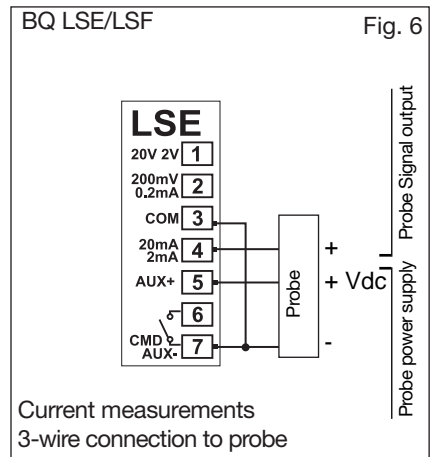
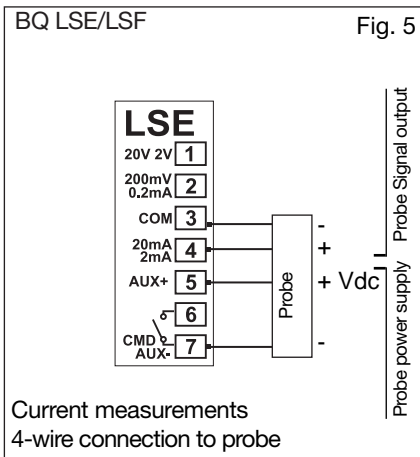
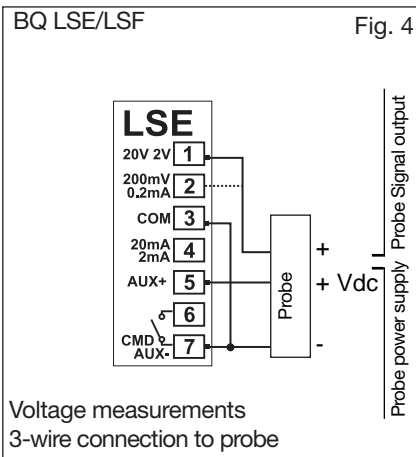
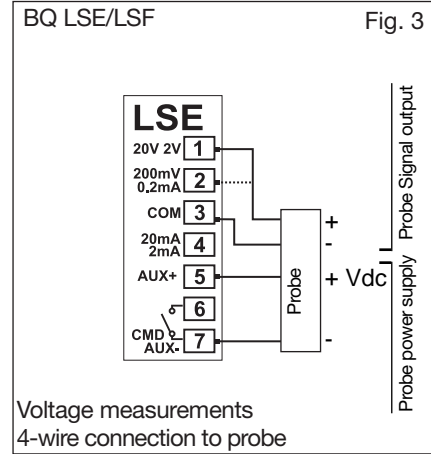
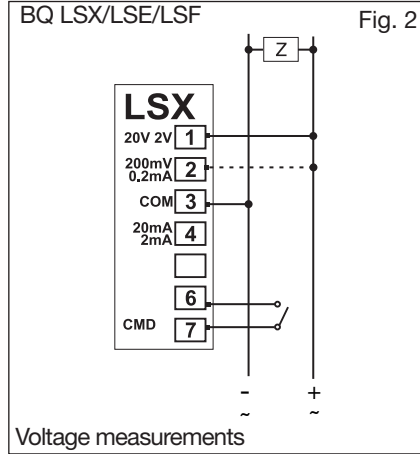
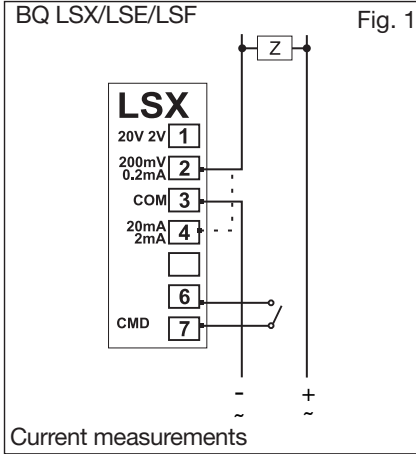

## Wirings for high-level signals

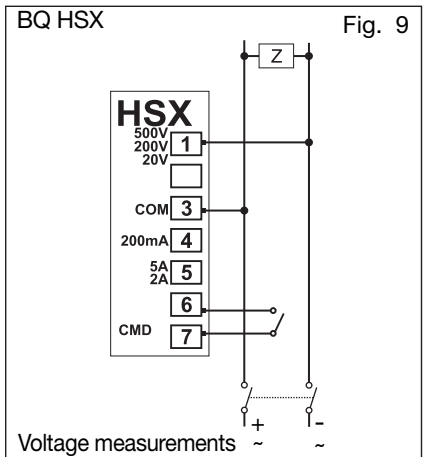
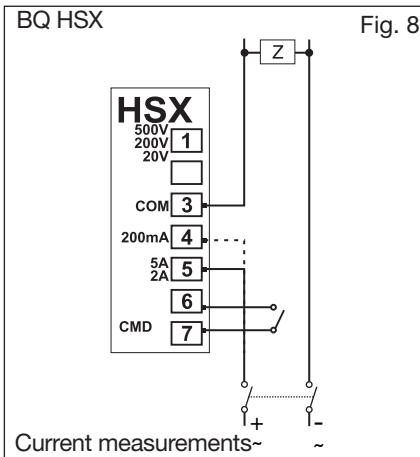
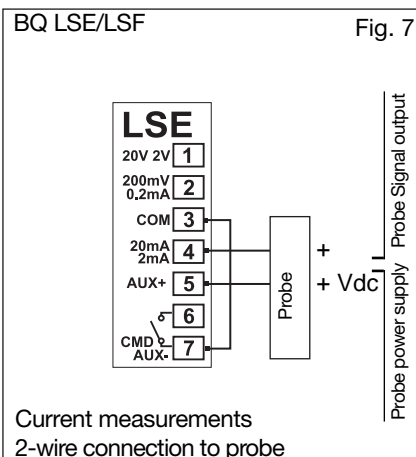

## Wiring diagrams (cont.)

### Wiring diagrams for temperature measurements

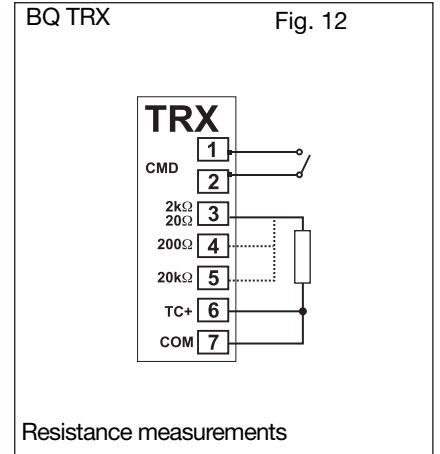
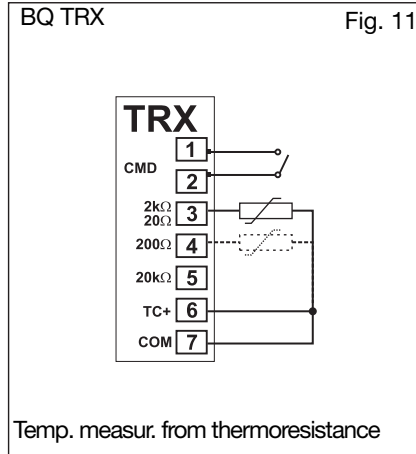
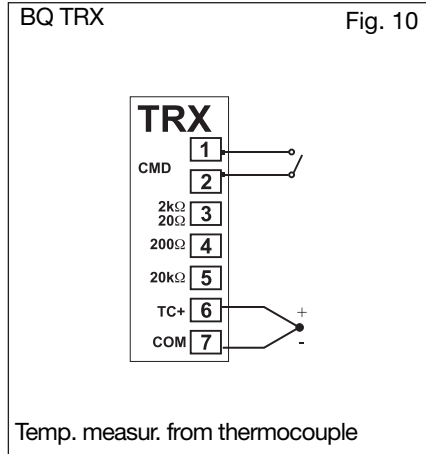

### Wiring diagrams for power supply

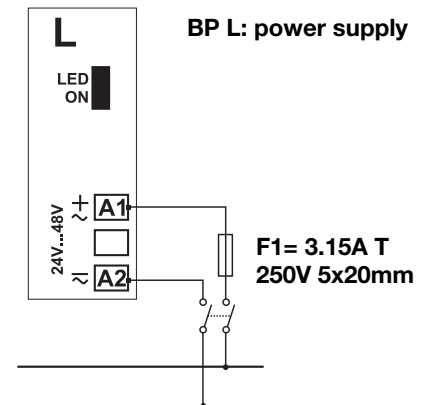
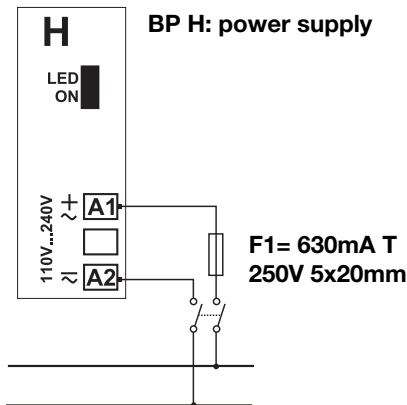

## Wiring diagrams of optional modules

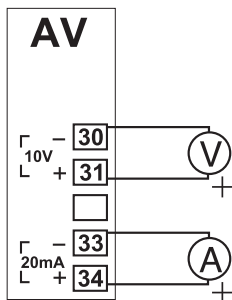

BO AV: single analogue output (10V, 20mA)

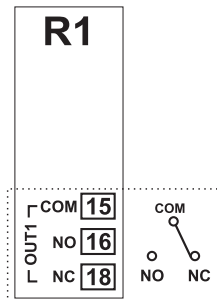

BO R1: 1 relay output

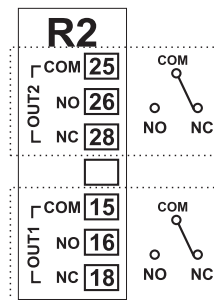

BO R2: 2 relay outputs

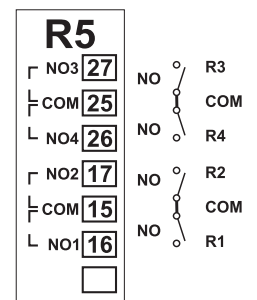

BO R5: 4 relay outputs

## Wiring diagrams of optional modules (cont.)

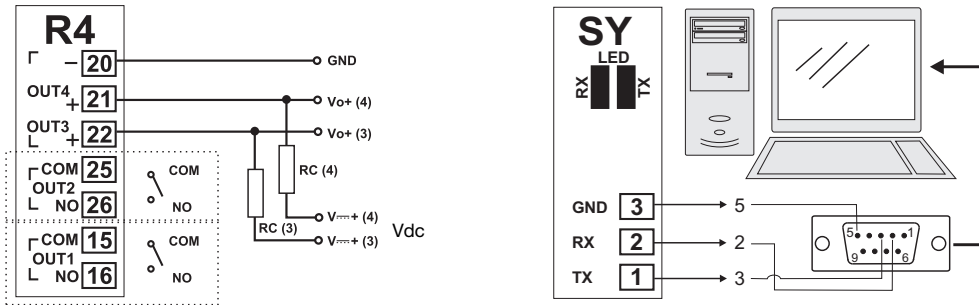

**BO SY:** RS232 direct connection to PC by means of COM port. RS232 has no termination.

**BO R4:** dual relay output +dual open collector output:

the load resistances (Rc) must be designed so that the close contact current is lower than 100mA; the VDC voltage must be lower than or equal to 30VDC.

VDC: power supply output

Vo+: positive output (open collector transistor).

GND: ground collector (open collector transistor).

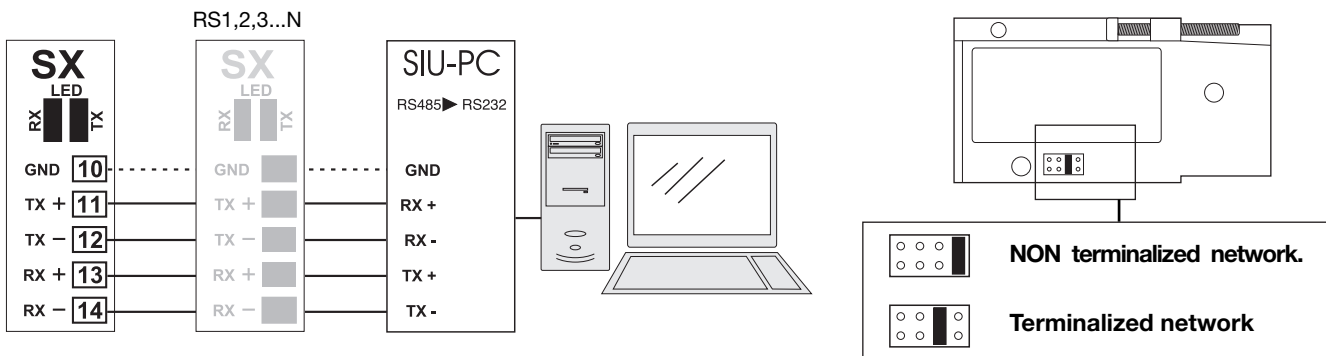

**BR SX: RS485 4-wire connection:** additional devices provided with RS485 port (indicated as RS1,2,3...N) are connected in parallel. The termination of the serial port is carried out only on the last instrument of the network. The serial module is provided with a jumper for the termination of the RS485 network as shown in the figure above.

**Note:** particular types of cables or plants may require an external termination. For the network connections use twisted cable type AWG26.

## Programming USC by means of PC

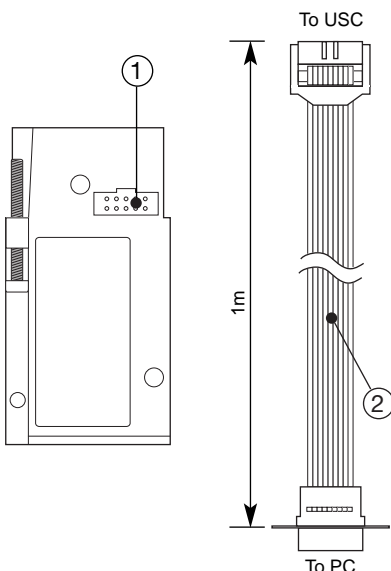

USC is programmable by PC by means of the UscSoft software (available on request). The user can program all parameters of USC that will be subsequently uploaded and set in the instrument by the RS485 network (BR SX).

Should USC be without the RS485 serial module, all programming parameters will be uploaded and set in the instrument by the RS232 auxiliary serial connection (1) located on the side of the measuring input module using the special connection cable (2) available on request, as shown in the figures on the left. It is also possible to program the instrument using the connector (1) by means of the HyperTerminal Windows functions of a PC.

**Note:** the RS232 auxiliary port IS NOT insulated from the measuring inputs.

Ordering code of the cable (2): UCOM1

## Dimensions

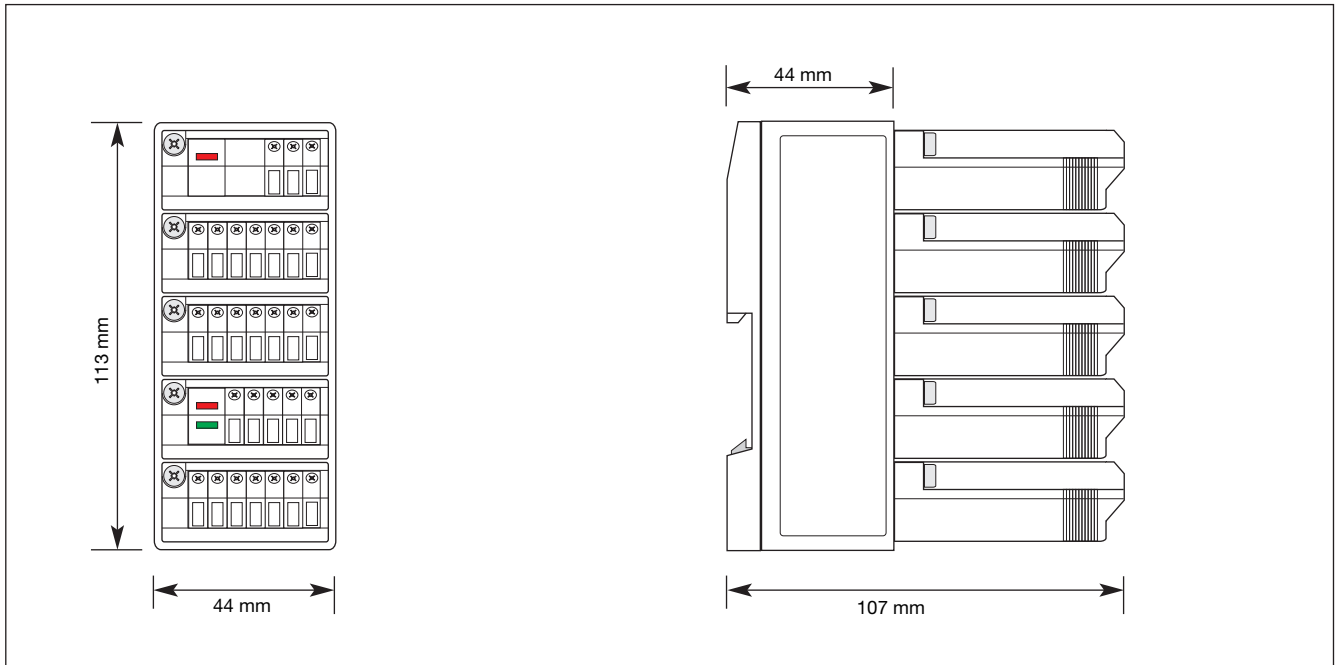

## Dimensions of optional module in scale 1:1

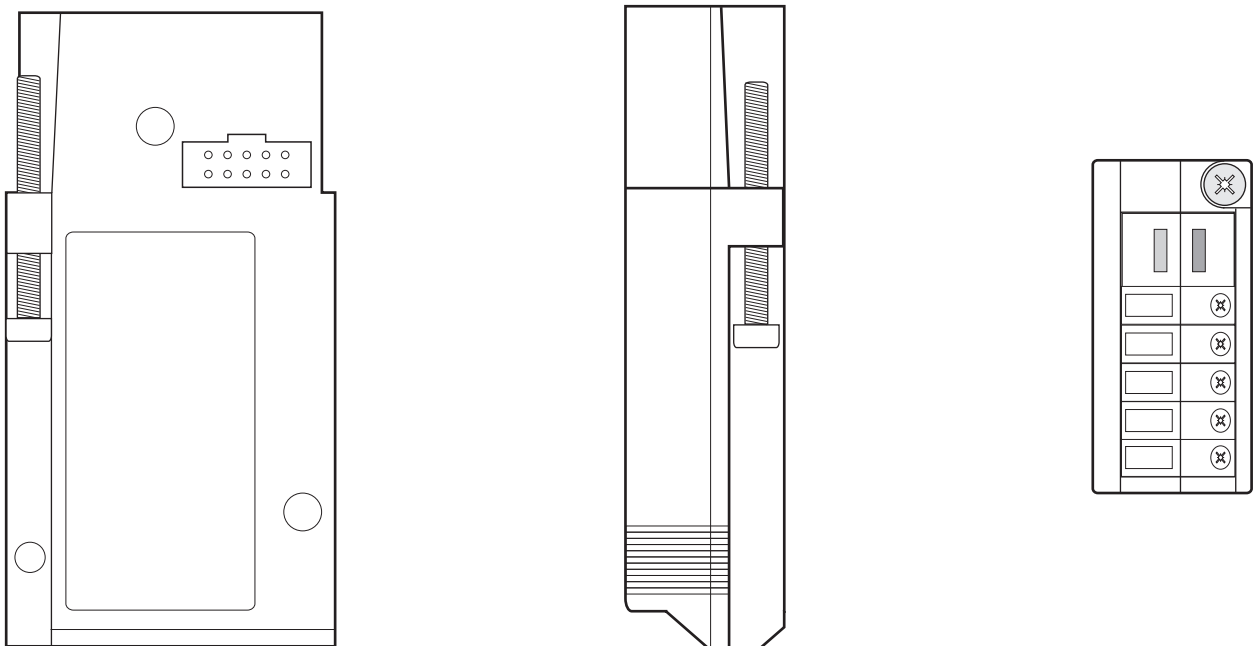

# Modules

## Input modules

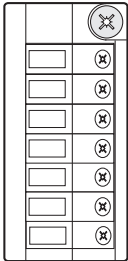

**BQ LSX, BQ LSE,  
BQ LSF, BQ HSX,  
BQ TRX**  
Measuring inputs

## Output modules

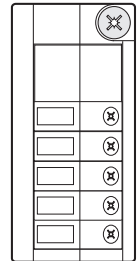

**BO AV**  
Single analogue  
output 10V, 20mA

## Output modules

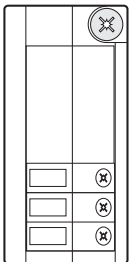

**BO R1**  
Single relay output

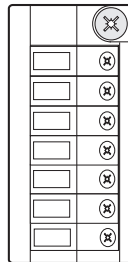

**BO R2**  
Dual relay output

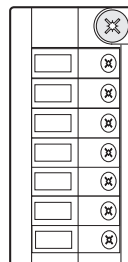

**BO R4**  
Dual relay output +  
Dual open collector

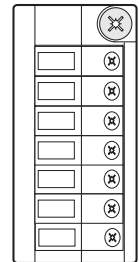

**BO R5**  
4-relay output

## Serial port modules

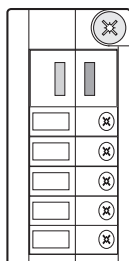

**BR SX**  
RS485 Serial port

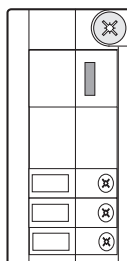

**BR SY**  
RS232 Serial port

## Power supply modules

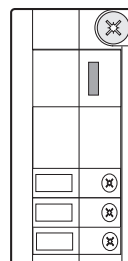

**BP H**  
Power supply:  
60 to 260V AC/DC

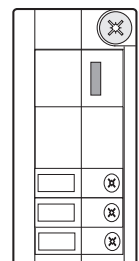

**BP L**  
Power supply:  
18 to 60V AC/DC