

# Energy Management Energy Meter Type EM21 72D



- Certified according to MID Directive (option PF only): see "how to order" below
- Other versions available (not certified, option X and P): see "how to order" on the next page.

- Class B (kWh) according to EN50470-3
- Class 1 (kWh) according to EN62053-21
- Class 2 (kvarh) according to EN62053-23
- Accuracy  $\pm 0.5$  RDG (current/voltage)
- Energy meter
- Instantaneous variables readout: 3 DGT
- Energies readout: 6+1 DGT
- System variables: W, var, PF, Hz, Phase-sequence.
- Single phase variables:  $V_{LL}$ ,  $V_{LN}$ , A, PF
- Energy measurements: total kWh and kvarh
- TRMS measurements of distorted sine waves (voltages/currents)
- Self power supply
- Dimensions: 4-DIN modules and 72x72mm
- Protection degree (front): IP50
- Application adaptable display and programming procedure (Easyprog function)
- Easy connections management
- Detachable display
- Multi-use housing: for both DIN-rail and panel mounting applications

## Product Description

Three-phase energy meter with removable front LCD display unit. The same unit can be used either as a DIN-rail mounting or a panel mounting energy meter. This general purpose three-phase energy meter

is suitable for both active and reactive energy metering for cost allocation but also for main electrical parameter measurement and retransmission (transducer function). Housing for DIN-rail mounting with IP50

(front) protection degree. Current measurements carried out by means of external current transformers and voltage measurements carried out either by means of direct connection or by means of potential trans-

formers. EM21-72D is provided, as standard, with a pulsating output for active energy retransmission. In addition a 2-wire RS485 communication port is available as an option.

**MID** Certified according to MID Directive, Annex "B" + Annex "D" or Annex "B" + Annex "F" for legal metrology relevant to active electrical energy meters (see Annex MI-003 of MID). Can be used for fiscal (legal) metrology.

## How to order EM21 72D AV5 3 X O X PF

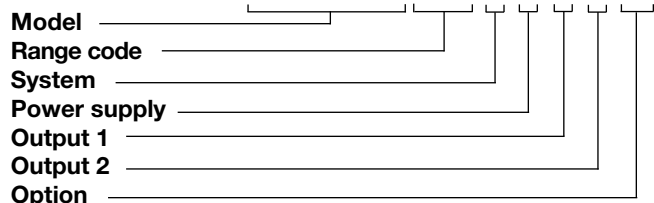

## Type Selection

Range codes	System	Power supply	Options
<b>AV5:</b> 400V <sub>LL</sub> AC, 5(6)A (CT connection) <b>AV6:</b> 120V <sub>LN</sub> /230V <sub>LL</sub> AC 5(6)A (VT/PT and CT connections)	<b>3:</b> balanced and unbalanced load: 3-phase, 4-wire; 3-phase, 3-wire; 2-phase, 3-wire; 1-phase, 2-wire	<b>X:</b> Self power supply from 18V to 260VAC VLN, 45 to 65 Hz (connection VL1-N)	<b>PF:</b> Certified according to MID Directive, Annex "B" + Annex "D" or Annex "B" + Annex "F" for legal metrology relevant to active electrical energy meters (see Annex MI-003 of MID). Can be used for fiscal (legal) metrology.
Output 1	Output 2		
<b>O:</b> Single static output (opto-mosfet)	<b>X:</b> None <b>S:</b> RS485 port		

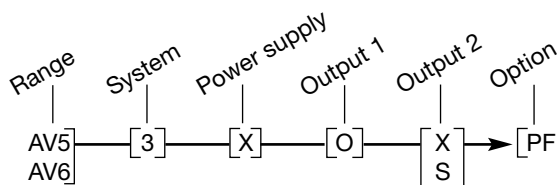

**NOTE:** please check the availability of the needed code on the verification path diagram on left before order .



**STANDARD**

Not certified according to MID directive. Cannot be used for fiscal (legal) metrology.

**How to order EM21 72D AV5 3 X O X X**

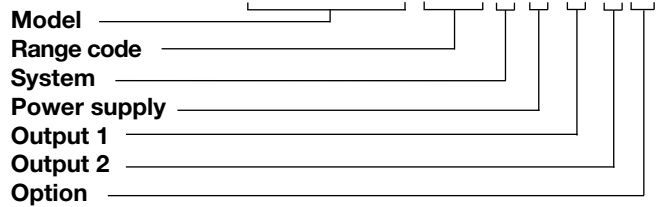

**Type Selection**

Range codes	System	Power supply	Options
<b>AV5:</b> 400V <sub>LL</sub> AC, 5(6)A or 1(6)A (*) (CT connection) <b>AV6:</b> 120V <sub>LN</sub> /230V <sub>LL</sub> AC 5(6)A or 1(6)A (*) (VT/PT and CT connections)	<b>3:</b> balanced and unbalanced load: 3-phase, 4-wire; 3-phase, 3-wire; 2-phase, 3-wire; 1-phase, 2-wire	<b>X:</b> Self power supply from 18V to 260VAC VLN, 45 to 65 Hz (connection VL1-N)	<b>X:</b> None <b>P:</b> Bearing EC. "Type examination" (annex B of MID) relevant to active electrical energy meters (see Annex MI-003).

Output 1	Output 2
<b>O:</b> Single static output (opto-mosfet)	<b>X:</b> None <b>S:</b> RS485 port

(\*) the range 1(6)A is available but not in compliance with the EN50470-3 standard.

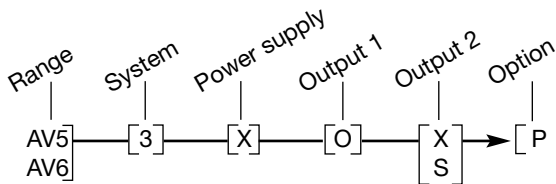

**NOTE:** please check the availability of the needed code on the verification path diagram on left before order .

## Input specifications

<b>Rated inputs</b>	System type: 3 Not isolated (shunt inputs). Note: the external current transformers can be connected to earth individually.	Energies	Imported Total: 6+1DGT or 7DGT
Current type		Overload status	EEE indication when the value being measured is exceeding the "Continuous inputs overload" (maximum measurement capacity)
Current range (by CT)	AV5 and AV6: 5(6)A. The "1(6)A" range is available but not in compliance with the EN50470-3 standard.	Max. and Min. indication	Max. instantaneous variables: 999; energies: 999 999.9 or 9 999 999. Min. instantaneous variables: 0; energies 0.0.
Voltage (direct or by VT/PT)	AV5: 400VLL; AV6: 120/230VLL		
<b>Accuracy</b> (Display + RS485) (@25°C ±5°C, R.H. ≤60%, 48 to 62 Hz)	In: see below, Un: see below	<b>LEDs</b>	Red LED (Energy consumption) 0.001 kWh by pulse if CT ratio x VT ratio is <7; 0.01 kWh by pulse if CT ratio x VT ratio is ≥ 7.0 < 70.0; 0.1 kWh by pulse if CT ratio x VT ratio is ≥ 70.0 < 700.0; 1 kWh by pulse if CT ratio x VT ratio is ≥ 700.0
AV5 model	In: 5A, I <sub>max</sub> : 6A; Un: 160 to 260VLN (277 to 450VLL).	Max frequency	16Hz, according to EN50470-3 Green LED (on the terminal blocks side) for power on (steady) and communication status: RX-TX (in case of RS485 option only) blinking.
AV6 model	In: 5A, I <sub>max</sub> : 6A; Un: 40 to 144VLN (70 to 250VLL).		
Current AV5, AV6 models	From 0.002I <sub>n</sub> to 0.2I <sub>n</sub> : ±(0.5% RDG +3DGT). From 0.2I <sub>n</sub> to I <sub>max</sub> : ±(0.5% RDG +1DGT).		
Phase-neutral voltage	In the range Un: ±(0,5% RDG +1DGT).		
Phase-phase voltage	In the range Un: ±(1% RDG +1DGT).		
Frequency	Range: 45 to 65Hz; resolution: ±1Hz		
Active power	±(1%RDG +2DGT).		
Power Factor	±[0.001+1%(1.000 - "PF RDG")].		
Reactive power	±(2%RDG +2DGT).		
Active energy	class B according to EN50470-1-3; class 1 according to EN62053-21.		
Reactive energy	class 2 according to EN62053-23. In: 5A, I <sub>max</sub> : 6A; 0.1 In: 0.5A. Start up current: 10mA.		
<b>Energy additional errors</b>		<b>Measurements</b>	See "List of the variables that can be connected to:"
Influence quantities	According to EN62053-21, EN50470-1-3, EN62053-23	Method	TRMS measurements of distorted wave forms.
<b>Temperature drift</b>	≤200ppm/°C.	Coupling type	By means of external CT's.
<b>Sampling rate</b>	1600 samples/s @ 50Hz, 1900 samples/s @ 60Hz	<b>Crest factor</b>	In 5A: ≤3 (15A max. peak).
<b>Display refresh time</b>	1 second	<b>Current Overloads</b>	
<b>Display</b>	2 lines 1 <sup>st</sup> line: 7-DGT, 2 <sup>nd</sup> line: 3-DGT or 1 <sup>st</sup> line: 3-DGT + 3-DGT, 2 <sup>nd</sup> line: 3-DGT.	Continuous	6A, @ 50Hz.
Type	LCD, h 7mm.	For 500ms	120A, @ 50Hz.
Instantaneous variables read-out	3-DGT.	<b>Voltage Overloads</b>	
		Continuous	1.2 Un
		For 500ms	2 Un
		<b>Current input impedance</b>	
		5(6)A	< 0.3VA
		<b>Voltage input impedance</b>	
		Self-power supply	Power consumption: <2VA.
		<b>Frequency</b>	45 to 65 Hz.
		<b>Key-pad</b>	Two push buttons for variable selection and programming of the instrument working parameters.

## Output specifications

<b>Pulse output</b>			
Number of outputs	1	Addresses	on the instrument. 247, selectable by means of the front keypad
Type	Programmable from 0.01 to 9.99 kWh per pulses. Output connectable to the energy meters (kWh)	Protocol	MODBUS/JBUS (RTU)
Pulse duration	$\geq 100\text{ms} < 120\text{ms}$ (ON), $\geq 120\text{ms}$ (OFF), according to EN62052-31.	Data (bidirectional)	System and phase variables: see table "List of variables..."
Output Load	Static: opto-mosfet. $V_{\text{ON}}$ 2.5 VAC/DC max. 70 mA, $V_{\text{OFF}}$ 260 VAC/DC max.	Dynamic (reading only)	All the configuration parameters.
Insulation	By means of optocouplers, 4000 VRMS output to measuring inputs.	Static (reading and writing)	1 start bit, 8 data bit, no parity, 1 stop bit.
<b>RS485</b>		Data format	9600 bits/s.
Type	Multidrop, bidirectional (static and dynamic variables)	Baud-rate	1/5 unit load. Maximum 160 transceiver on the same bus.
Connections	2-wire. Max. distance 1000m, termination directly	Driver input capability	By means of optocouplers, 4000 VRMS output to measuring input.
		Insulation	

## Software functions

<b>Password</b>		<b>Transformer ratio</b>	
	Numeric code of max. 3 digits; 2 protection levels of the programming data:	VT (PT)	1.0 to 99.9 / 100 to 999 / 1.00k to 6.00k
1st level	Password "0", no protection;	CT	1.0 to 99.9 / 100 to 999 / 1.00k to 9.99k / 10.0k to 60.0k.
2nd level	Password from 1 to 999, all data are protected		The maximum power being measured cannot exceed 210 MW calculated as maximum input voltage and current, (see the "Accuracy" paragraph).
Programming lock	By means of potentiometer (back-side of the display module) it is possible to lock the access to all the configuration parameters.		The maximum VT by CT ratio is 48.600. For MID complaint applications the maximum power being measured is 25 MW.
<b>System selection</b>		<b>Displaying</b>	Up to 3 variables per page. See « Display pages », 3 different set of variables available (see « Display pages ») according to the metering function being selected.
System 3-Ph.n unbalanced load	3-phase (4-wire) 3-phase (3-wire)	<b>Reset</b>	By means of the front keypad: total energies (kWh, kvarh).
System 3-Ph.1 balanced load	• 3-phase (3-wire) one current and 3-phase to phase voltage measurements. Note: the phase to phase voltage is calculated multiplying by 1.73 the virtual phase to neutral voltage. • 3-phase (4-wire) one current and 3-phase to neutral voltage measurements. Note: the phase to phase voltage is calculated multiplying by 1.73 the virtual phase to neutral voltage. • 3-phase (2-wire) one current and 1-phase (L1) to neutral voltage measurement.	<b>Easy connection function</b>	Wrong phase detection and displaying. For all the display selections, both energy measurements are dependent from the current direction, both power measurements are independent from the current direction. The power measurements are always positive.
System 2-Ph	2-phase (3-wire)		
System 1-Ph	1-phase (2-wire)		

## General specifications

<b>Operating temperature</b>	-25°C to +55°C (-13°F to 131°F) (R.H. from 0 to 90% non-condensing @ 40°C) according to EN62053-21 and EN62053-23.	<b>Surge</b>	On current and voltage measuring inputs circuit: 6kV;
<b>Storage temperature</b>	-30°C to +70°C (-22°F to 158°F) (R.H. < 90% non-condensing @ 40°C) according to EN62053-21 and EN62053-23.	<b>Radio frequency suppression</b>	According to CISPR 22
<b>Installation category</b>	Cat. III (IEC60664, EN60664).	<b>Standard compliance</b>	
<b>Insulation (for 1 minute)</b>	4000 VRMS between measuring inputs and digital output.	<b>Safety</b>	IEC60664, IEC61010-1 EN60664, EN61010-1 EN62052-11
<b>Dielectric strength</b>	4000 VRMS for 1 minute.	<b>Metrology</b>	EN62053-21, EN62053-23, EN50470-3
<b>Noise rejection CMRR</b>	100 dB, 48 to 62 Hz.	<b>Pulse output Approvals</b>	DIN43864, IEC62053-31 CE, cULus listed, MID (PF option only)
<b>EMC</b>	According to EN62052-11	<b>Connections</b>	Screw-type
Electrostatic discharges	15kV air discharge;	Cable cross-section area	2.4 x 3.5 mm
Immunity to irradiated	Test with current: 10V/m from 80 to 2000MHz;		Min./Max. screws tightening torque: 0.4 Nm / 0.8 Nm
Electromagnetic fields	Test without any current: 30V/m from 80 to 2000MHz;	<b>Housing</b>	
Burst	On current and voltage measuring inputs circuit: 4kV	Dimensions (WxHxD)	72 x 72 x 65 mm
Immunity to conducted disturbances	10V/m from 150KHz to 80MHz	Material	Noryl PA66, self-extinguishing: UL 94 V-0 Panel and DIN-rail
		Mounting	
		<b>Protection degree</b>	
		Front	IP50
		Screw terminals	IP20
		<b>Weight</b>	Approx. 400 g (packing included)

## Power supply specifications

<b>Self power supply</b>	18 to 260VAC (48-62Hz). Across input "VL1" and "N"	<b>Power consumption</b>	≤2VA/1W
--------------------------	--	--------------------------	---------

## Insulation between inputs and outputs

	Measuring Inputs	Opto-Mosfet output	Communication port	Self power supply
Measuring Inputs	-	4kV	4kV	0kV
Opto-Mosfet output	4kV	-	-	4kV
Communication port	4kV	-	-	4kV
Self power supply	0kV	4kV	4kV	-

**NOTE:** all the models have, mandatorily, to be connected to external current transformers.

## Accuracy (According to EN50470-3 and EN62053-23)

kWh, accuracy (RDG) depending on the current

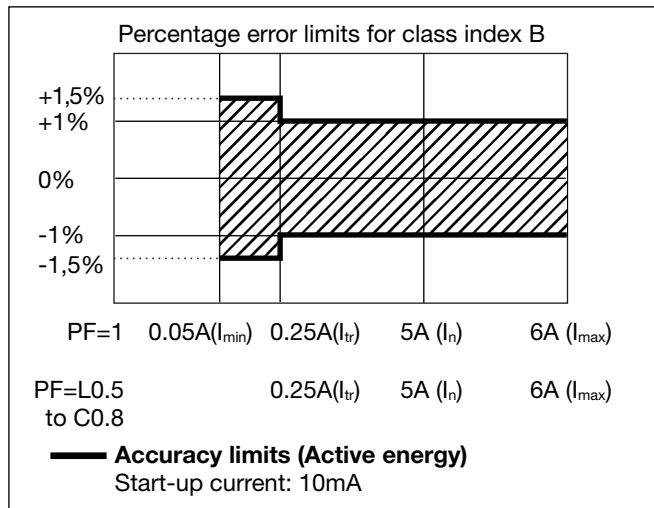

kvarh, accuracy (RDG) depending on the current

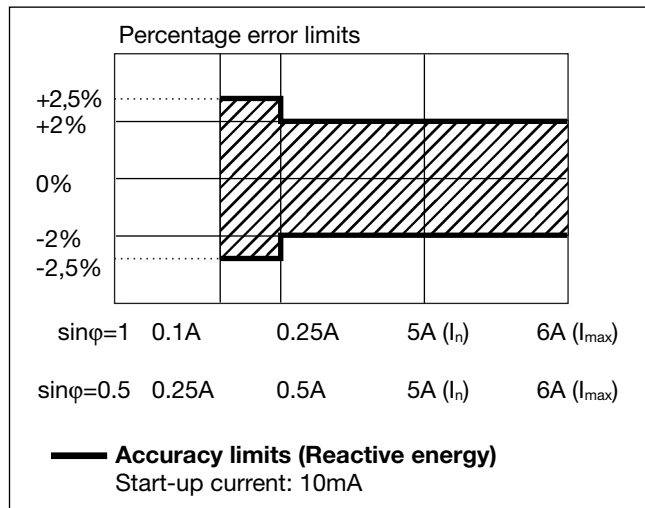

## MID "Annex MI-003" compliance (PF option only)

Accuracy

0.9 U<sub>n</sub> ≤ U ≤ 1.1 U<sub>n</sub>;  
0.98 f<sub>n</sub> ≤ f ≤ 1.02 f<sub>n</sub>;  
f<sub>n</sub>: 50Hz;  
cosφ: 0.5 inductive to 0.8 capacitive.  
Class B I st: 0.01A; I min:  
0.05A; I tr: 0.25A; I n: 5A  
I max: 6A.

Operating temperature

-25°C to +55°C (-13°F to  
131°F) (R.H. from 0 to 90%)

non-condensing @ 40°C)

EMC compliance

E2

Mechanical compliance

M2

Protection degree

in order to achieve the protection against dust and water required by the norms harmonized to MID, the meter must be used only installed in IP51 (or better) cabinets.

## Used calculation formulas

Phase variables

Instantaneous effective voltage

$$V_{1N} = \sqrt{\frac{1}{n} \cdot \sum_1^n (V_{1N})_i^2}$$

Instantaneous active power

$$W_1 = \frac{1}{n} \cdot \sum_1^n (V_{1N})_i \cdot (A_1)_i$$

Instantaneous power factor

$$\cos\varphi_1 = \frac{W_1}{VA_1}$$

Instantaneous effective current

$$A_1 = \sqrt{\frac{1}{n} \cdot \sum_1^n (A_1)_i^2}$$

Instantaneous apparent power

$$VA_1 = V_{1N} \cdot A_1$$

Instantaneous reactive power

$$\text{var}_1 = \sqrt{(VA_1)^2 - (W_1)^2}$$

System variables

Equivalent three-phase voltage

$$V_\Sigma = \frac{V_1 + V_2 + V_3}{3} \cdot \sqrt{3}$$

Voltage asymmetry

Three-phase active power

$$W_\Sigma = W_1 + W_2 + W_3$$

Three-phase apparent power

$$VA_\Sigma = \sqrt{W_\Sigma^2 + \text{var}_\Sigma^2}$$

Three-phase power factor

$$\cos\varphi_\Sigma = \frac{W_\Sigma}{VA_\Sigma} \quad (\text{TPF})$$

Energy metering

$$k \text{ var } hi = \int_{n_1}^{n_2} Qi(t) dt \cong \Delta t \sum_{n_1}^{n_2} Qnj$$

$$kWhi = \int_{n_1}^{n_2} Pi(t) dt \cong \Delta t \sum_{n_1}^{n_2} Pnj$$

Where:

**i**= considered phase (L1, L2 or L3)  
**P**= active power; **Q**= reactive power;  
**t<sub>1</sub>**, **t<sub>2</sub>**= starting and ending time points of consumption recording; **n**= time unit; **Δt**= time interval between two successive power consumptions;  
**n<sub>1</sub>**, **n<sub>2</sub>**= starting and ending discrete time points of consumption recording

## List of the variables that can be connected to:

- RS485 communication port
- Pulse outputs (only “energies”)

No	Variable	1-ph. sys.	2-ph. sys.	3-ph. 4-wire balanced system	3-ph. 3-wir balanced system	3-ph. 4-wire unbalanced system	3-ph. 3-wir unbalanced system	Notes
1	kWh	x	x	x	x	x	x	Total
2	kvarh	x	x	x	x	x	x	Total
3	V L-N sys (1)	o	x	x	x	x	x	sys=system ( $\Sigma$ )
4	V L1	x	x	x	x	x	x	
5	V L2	o	x	x	x	x	x	
6	V L3	o	o	x	x	x	x	
7	V L-L sys (1)	o	x	x	x	x	x	sys=system ( $\Sigma$ )
8	V L1-2	o	x	x	x	x	x	
9	V L2-3	o	o	x	x	x	x	
10	V L3-1	o	o	x	x	x	x	
11	A L1	x	x	x	x	x	x	
12	A L2	o	x	x	x	x	x	
13	A L3	o	o	x	x	x	x	
14	VA sys (1)	x	x	x	x	x	x	sys=system ( $\Sigma$ )
15	VA L1 (1)	x	x	x	x	x	x	
16	VA L2 (1)	o	x	x	x	x	x	
17	VA L3 (1)	o	o	x	x	x	x	
18	var sys	x	x	x	x	x	x	sys=system ( $\Sigma$ )
19	var L1 (1)	x	x	x	x	x	x	
20	var L2 (1)	o	x	x	x	x	x	
21	var L3 (1)	o	o	x	x	x	x	
22	W sys	x	x	x	x	x	x	sys=system ( $\Sigma$ )
23	W L1 (1)	x	x	x	x	x	x	
24	W L2 (1)	o	x	x	x	x	x	
25	W L3 (1)	o	o	x	x	x	x	
26	PF sys	x	x	x	x	x	x	sys=system ( $\Sigma$ )
27	PF L1	x	x	x	x	x	x	
28	PF L2	o	x	x	x	x	x	
29	PF L3	o	o	x	x	x	x	
30	Hz	x	x	x	x	x	x	
31	Phase sequence	o	o	x	x	x	x	

(x) = available

(o) = not available (zero indication on the display)

(1) = Variable available only through the serial communication port RS485

## Display pages

No	1st variable (1 <sup>st</sup> half-line)	2nd variable (2 <sup>nd</sup> half-line)	3rd variable (2nd line)	Note	Applications		
					A	B	C
	Phase sequence			The phase sequence triangle appears in any page only if there is a phase reverse	x	x	x
1	Total kWh		W sys		x	x	x
2	Total kvarh		kvar sys			x	x
3		PF sys	Hz	Indication of C, -C, L, -L depending on the quadrant	x	x	x
4	PF L1	PF L2	PF L3	Indication of C, -C, L, -L depending on the quadrant			x
5	A L1	A L2	A L3				x
6	V L1-2	V L2-3	V L3-1				x
7	V L1	V L2	V L3				x

## Additional available information on the display

Type	1st line	2nd line	note
Meter information 1	Y. 2007	r.A0	Year of production and firmware release
Meter information 2	value	LEd (kWh)	KWh per pulse of the LED
Meter information 3	SYS [3P.n]	value	System type and connection type
Meter information 4	Ct rAt.	value	Current transformer ratio
Meter information 5	Ut rAt.	value	Voltage transformer ratio
Meter information 6	PuLSE (kWh)	value	Pulse output: kWh per pulse
Meter information 7	Add	value	Serial communication address

## List of selectable applications

	Description	Notes
<b>A</b>	Active energy meter	Active energy measurement with some minor parameters
<b>B</b>	Active and reactive energy meter	Active and reactive energy measurement with some minor parameters
<b>C</b>	Full set of variables	Full set of available variables can be displayed

## One instrument with double mounting capability

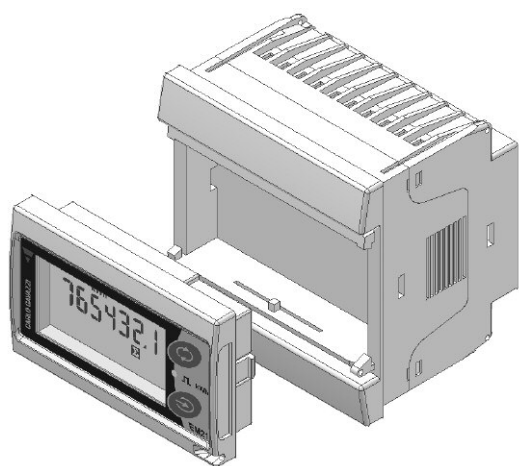

By means of the patented detachable display it is possible to configure the same instrument either as a panel mounting meter or...

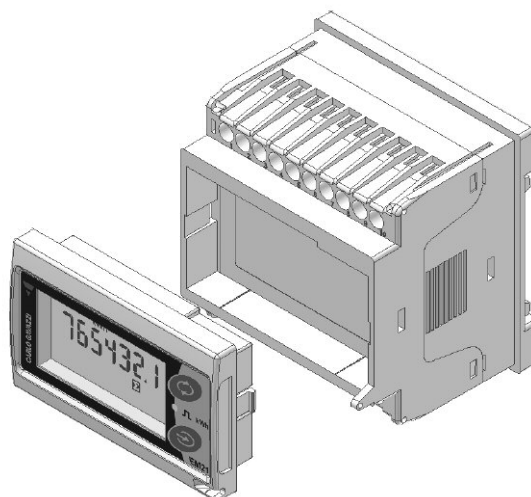

... as DIN-rail mounting meter.

# Wiring diagrams

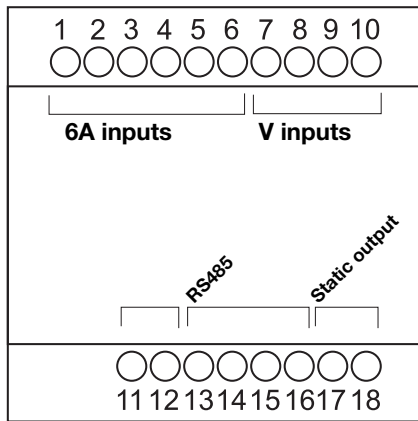

## (6A) Self power supply, system type selection: 3P.n

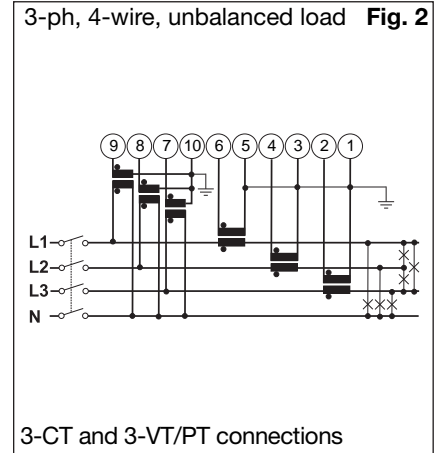
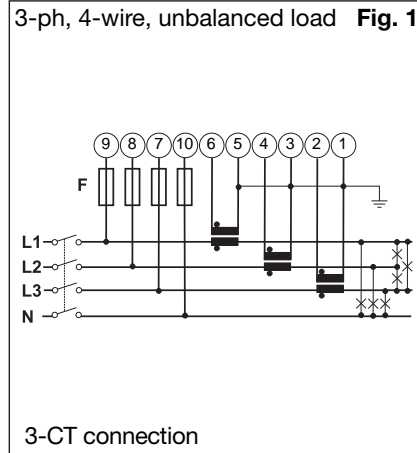

## (6A) System type selection: 3P.n

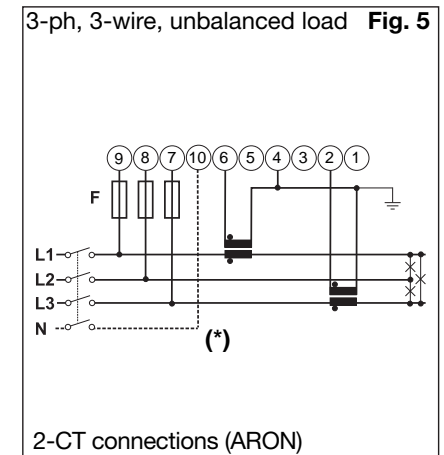
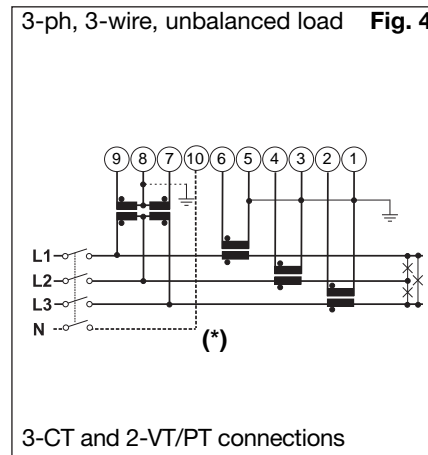
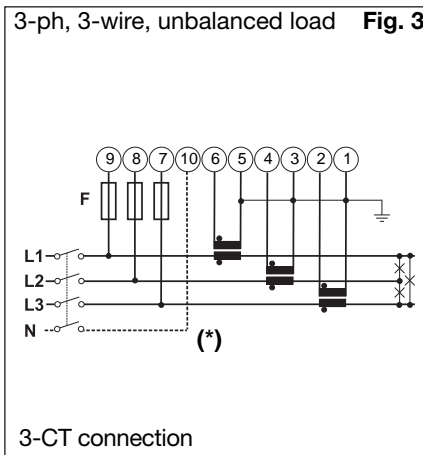

## (6A) Self power supply, system type selection: 3P.1

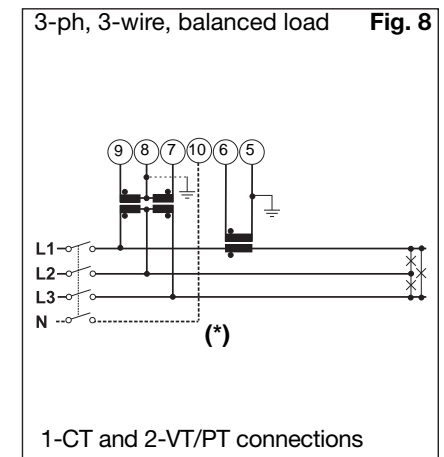
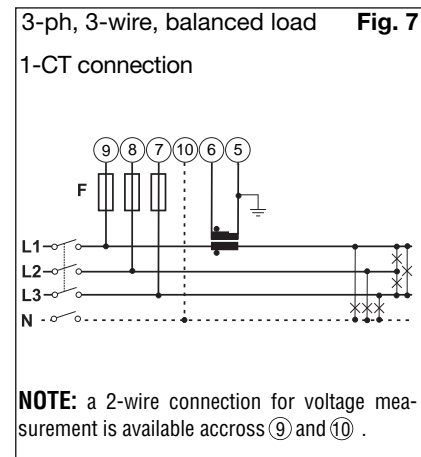
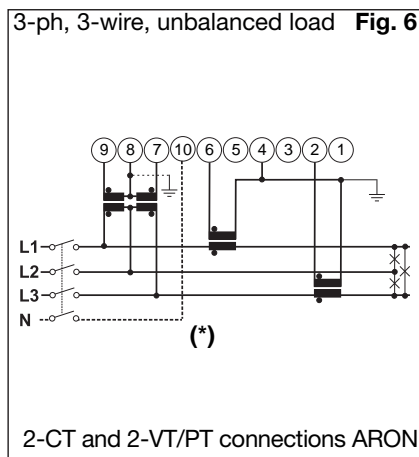

(\*) **NOTE:** For a correct power supply of the instrument, the neutral must always be connected.

## Wiring diagrams

(6A) System type selection: 2P

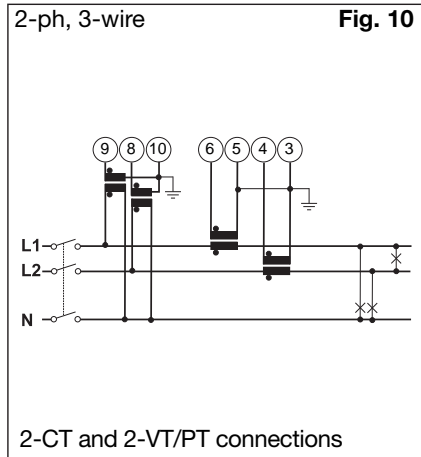
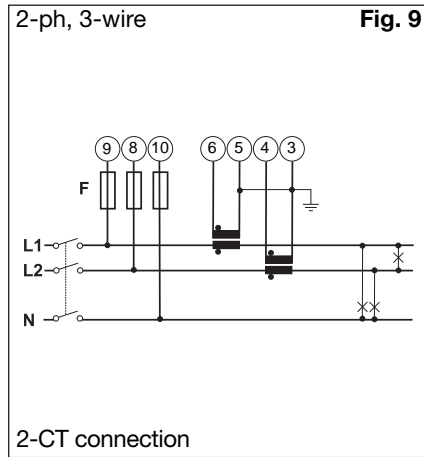

(6A) System type selection: 1P

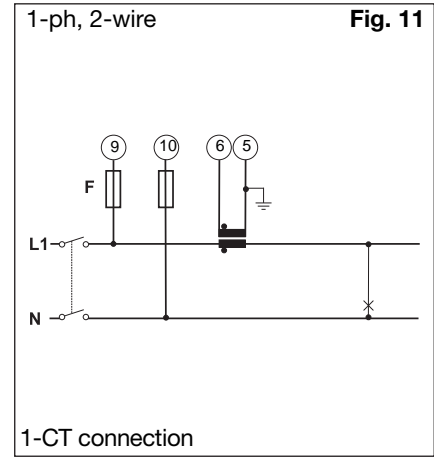

## Static output wiring diagram

(6A) System type selection: 1P

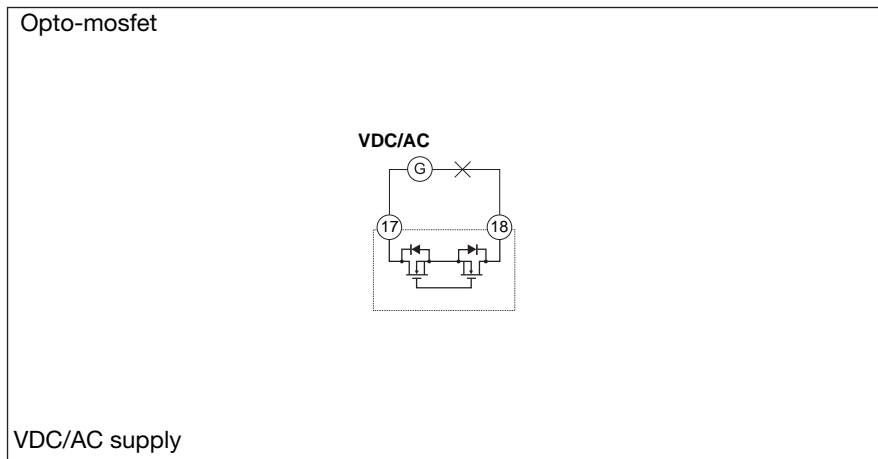
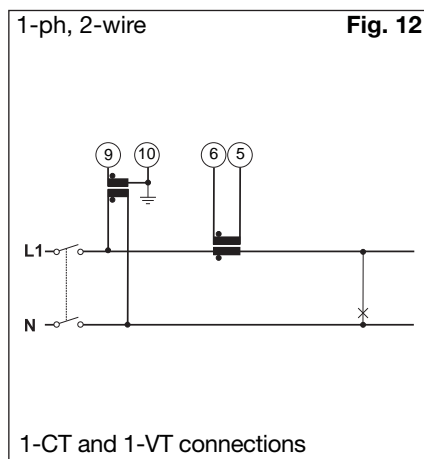

## RS485 port wiring diagram

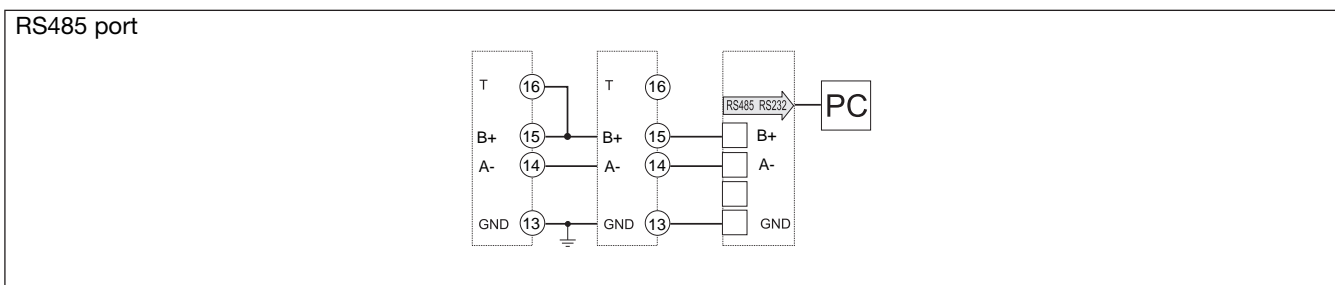

**RS485 NOTE:** additional devices provided with RS485 are connected as per the picture above. The termination of the serial output is carried out only on the last instrument of the network, by means of a jumper between (B+) and (T).

## Front panel description

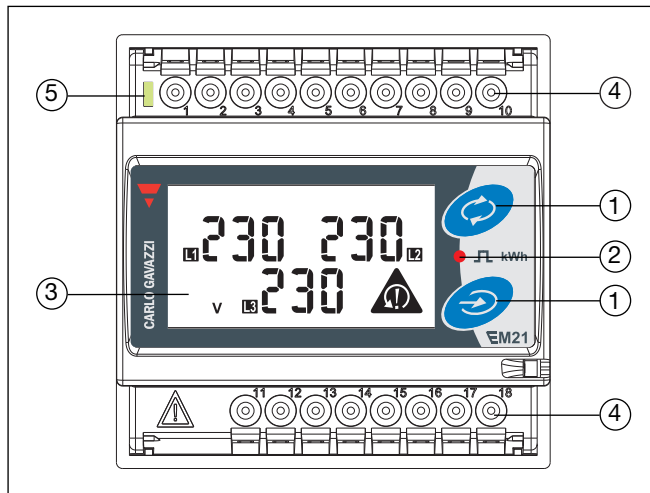

- 1. Keypad**  
To program the configuration parameters and scroll the variables on the display.
- 2. Pulse output LED**  
Red LED blinking proportional to the energy being measured.
- 3. Display**  
LCD-type with alphanumeric indications to display all the measured variables.
- 4. Connections**  
Screw terminal blocks for instrument wiring.
- 5. Green LED**  
Lit when power supply is available

## Dimensions (DIN configuration)

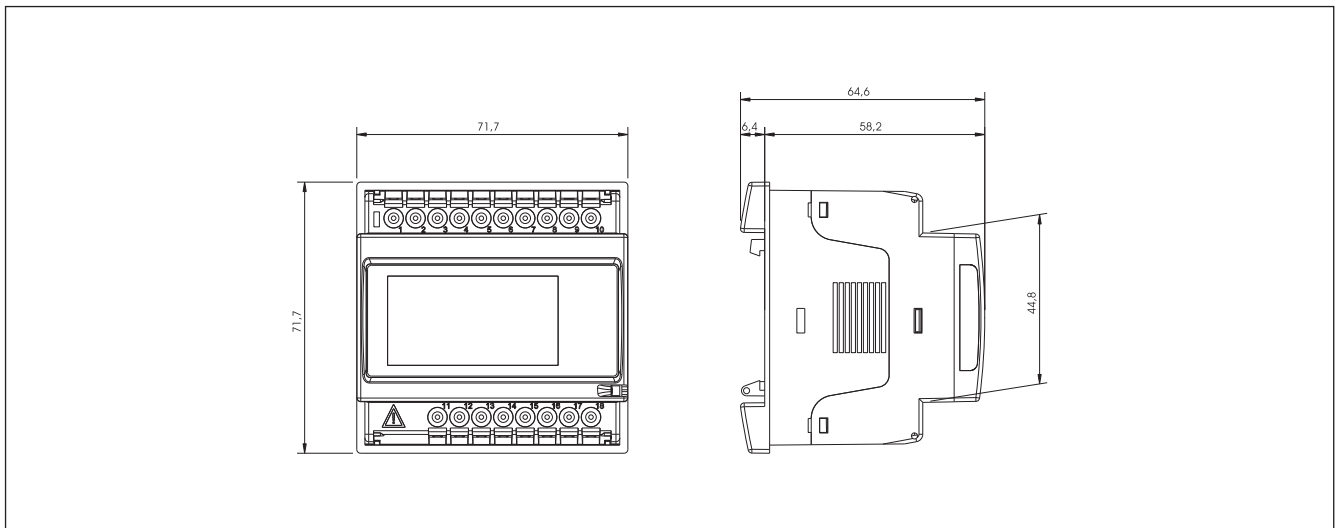

## Dimensions and panel cut out (72x72 panel mounting configuration)

